

VCarve Pro Reference Manual

VCarve Pro



Vetric
Passionate About CNC

Version 5.5

VCarve Pro

Disclaimer

All CNC machines (routing, engraving, and milling) are potentially dangerous and because Vectric Ltd has no control over how the software described in this manual might be used, Vectric Ltd or any associated Resellers cannot accept responsibility for any loss or damage to the work piece, machine or any individual, howsoever caused by misusing the software. Extreme care should always be taken and the output from the software thoroughly checked before sending it to a CNC machine.

The information in this manual may be subject to change without any prior notice. The software described in this manual is supplied under the terms and conditions of the software license agreement and may only be used in accordance with the terms of this agreement.

© Vectric Ltd
Unit 3 Dunstall Court
Astwood Lane
Feckenham
B96 6QH
UK

www.vectric.com

E-mail info@vectric.com
Phone +44 (0) 1527 460 459
Fax +44 (0) 1527 460 459

Table of Contents

INTRODUCTION	4
OVERVIEW OF THE INTERFACE.....	6
MANAGING WINDOWS - AUTO SHOW / HIDE	7
VIEW CONTROLS	8
FILE OPERATIONS - SETTING UP AND MANAGING THE PART	9
FILE OPERATIONS	10
2D DESIGN AND MANAGEMENT	15
OVERVIEW	15
VECTORS.....	15
BITMAPS.....	15
<i>Vector Import</i>	16
CREATING VECTORS	17
<i>Drawing Shapes</i>	17
<i>Draw Star</i>	17
<i>Creating Text</i>	18
<i>Plate Production</i>	18
<i>Fit Vectors to Bitmap</i>	19
VECTOR EDITING	20
<i>Vector Selection Mode</i>	20
<i>Node Editing Mode</i>	21
<i>Interactive Selection Mode</i>	22
<i>Group and Measure</i>	23
<i>Move, Scale, Rotate, Mirror and Duplicate</i>	26
<i>Nesting</i>	27
<i>Offset, Weld, Fillet and Curve Fit</i>	36
<i>Join and Close Vectors</i>	44
ALIGN OBJECTS	45
LAYER MANAGEMENT	47
<i>Layer Control Manager</i>	48
RULERS, GUIDELINES AND THE SNAP GRID.....	51
<i>Rulers</i>	51
<i>Guidelines</i>	51
<i>Snap Grid</i>	53
TOOLPATHS	56
OVERVIEW	56
THE TOOL DATABASE	57
USING FORM CUTTERS	61
THE TOOLPATH LIST	63
<i>Floating Toolpath List</i>	64
TOOLPATH OPERATIONS	65
MATERIAL SETUP.....	66
VCARVE TOOLPATH	68
PROFILE TOOLPATH.....	71
<i>Tabs (Bridges)</i>	73
<i>Corners</i>	76
<i>Lead In and Lead Out</i>	79
<i>Ramping</i>	81
<i>Machining Open Vectors</i>	83

POCKETING TOOLPATH	84
DRILLING TOOLPATH	88
TEXTURING TOOLPATH	90
INLAY TOOLPATHS.....	94
PRISM CARVING TOOLPATH	102
FLUTING TOOLPATH	105
QUICK ENGRAVING TOOLPATH	110
EDIT TOOLPATH.....	113
COPY TOOLPATH	113
DELETE TOOLPATH.....	114
ESTIMATED MACHINING TIMES	114
SAVING TOOLPATHS	116
<i>Automatic Tool Changing Support</i>	117
PREVIEWING TOOLPATHS	118
MULTI-COLORED TOOLPATH PREVIEW.....	120
WRAPPED ROTARY OUTPUT	125
MENUS	130
FILE MENU	130
EDIT MENU.....	132
VIEW MENU	138
GADGETS MENU (OPTIONAL).....	140
HELP MENU	143
RIGHT MOUSE CLICK MENUS	144
2D VIEW RIGHT MOUSE MENU	144
SPAN EDITING MENU	145
NODE EDITING MENU	145
GLOSSARY OF TERMINOLOGY	146
2D VIEW	146
3D VIEW	146
BITMAP	146
FILE	146
GRayscale	146
SHORT CUT KEYS	146
VECTOR	146
FREQUENTLY ASKED QUESTIONS	147
IS THERE A LIST OF ALL THE SHORT-CUT KEYS?	147
WHAT FILE FORMATS CAN BE USED?	148
WHERE CAN I GET HELP?	149

Introduction

This manual is designed to provide a list of all the functions, tools, menus and icons available within the VCarve Pro software package. It is intended as a Reference Manual and not a training guide. Training is best fulfilled by working through the VCarve Pro tutorials for 2D machining and VCarving and Tutorial Videos

This manual is intended as a support document to those resources, allowing particular functions or icons to be looked up.

In some cases where there may be a minimal explanation in this document, more in depth information may be available in the Help file that accompanies the software and can be accessed by clicking the Help drop down menu from the top menu and selecting Help Contents as shown in the image shown below:

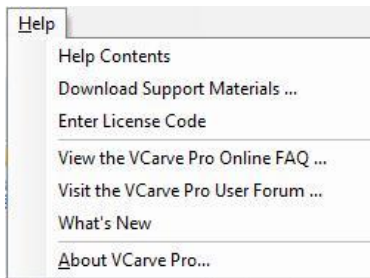

This manual is divided into logical sections which relate to specific areas of the software and the functions used within those areas. Refer to the table of contents for a specific list of the sections and contents.

We welcome any comments on this manual or the other training material, please email support@vetric.com with your feedback.

VCarve Pro includes drawing and editing tools that allow designs to be created and modified. Functions for vector creation and editing are very easy to use and multiple design elements can also be drawn or imported, scaled, positioned and interactively edited to make a new design. Text can also be created using any TrueType or OpenType font installed on your computer or the single stroke engraving fonts supplied with the software. Finally a comprehensive set of 2D, VCarving and 3D texturing toolpath strategies, provide you with efficient ways to apply your tooling to carve the finished part.

Overview of the interface

The screen area is split into 6 main regions.

- 1) The **Main Menu Bar** (the Drop Down Menus) along the top of the screen (File, Edit, View, Help) provide access to additional, less commonly used commands available in the software. Click on any of the choices to show a Drop-Down list of the functions.
- 2) The **Drawing Tab** on the left side of the screen provides general drawing tools for design modification, sizing, alignment and layer control of Vectors.
- 3) The **Toolpath Tab** on the right side of the screen is where toolpaths are defined, calculated, edited and deleted. The Material set-up and Job Preview tools are also in this area.
- 4) The **Command Forms** automatically appear in the Drawing window and the Toolpath tabs when tools are selected that require details to be entered such as dimensions for sizing or positioning etc.
- 5) The **2D Design window** is where the design is drawn, edited and selected ready for machining. Designs can be imported or created directly in VCarve Pro. This occupies the same area as the 3D View and the display can be toggled between the two using F2 and F3 or the tabs at the top of the window.
- 6) The **3D View** is where the 3D Toolpath job preview is displayed.

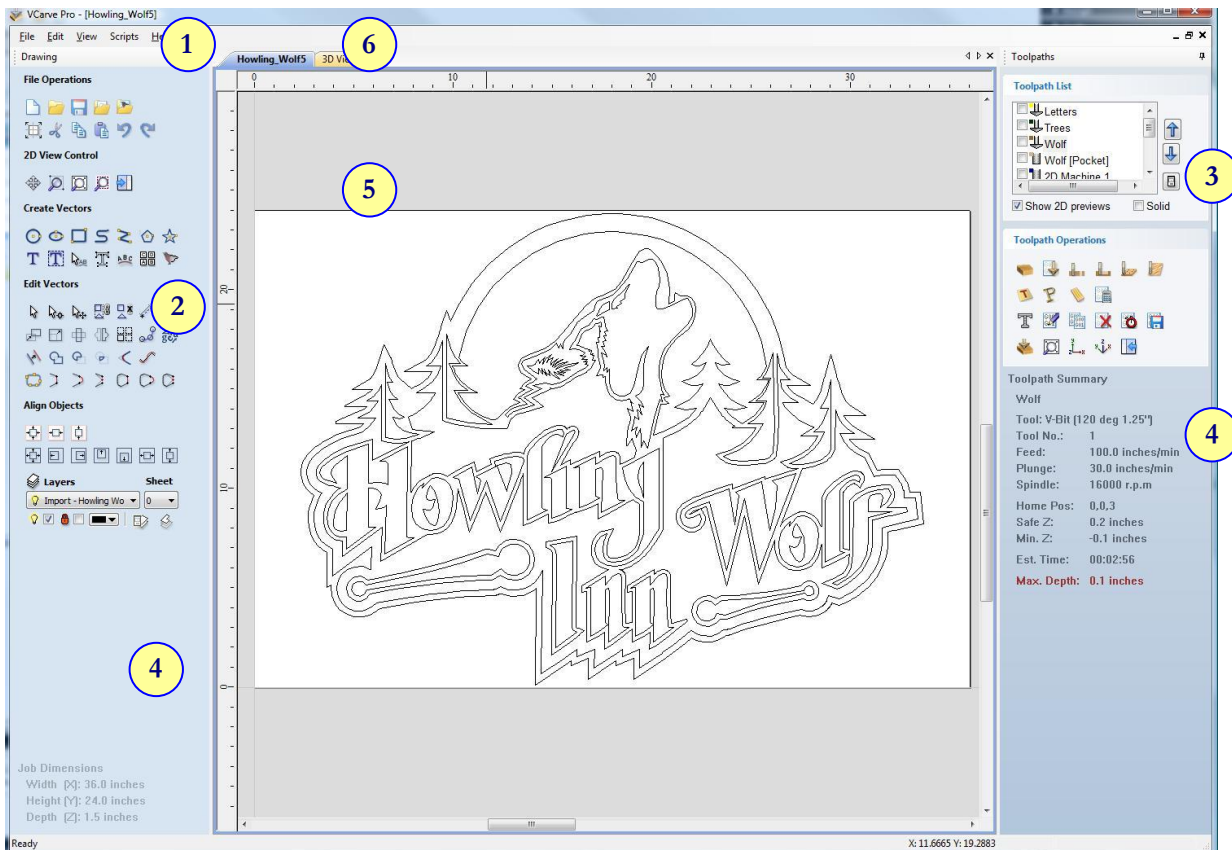

Managing windows - Auto Show / Hide

The two primary **Drawing** and **Toolpath Tabs** have Auto Hide / Show behaviour which allows them to automatically close when not being used, maximizing the working screen area. They can be opened and closed at any time by clicking the left mouse over the **Drawing** and **Toolpaths** tabs in the **top left** and **top right** corners of the interface. You can toggle between these two tabs by clicking **F11** to open the **Drawing Tab** or **F12** to open the **Toolpaths Tab**, the other will automatically be hidden when using these shortcut keys.

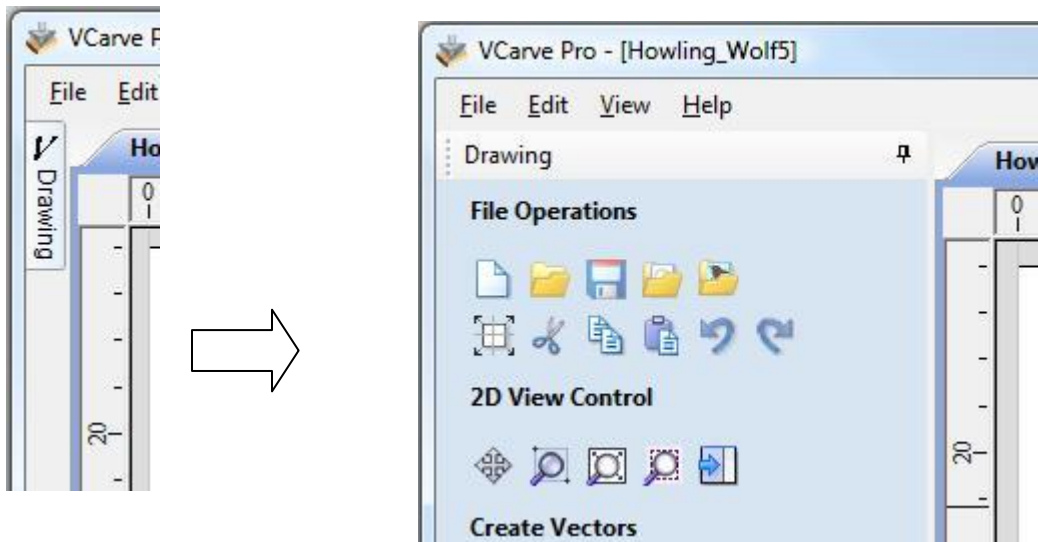

Click on the Drawing Tab to open the Drawing Window

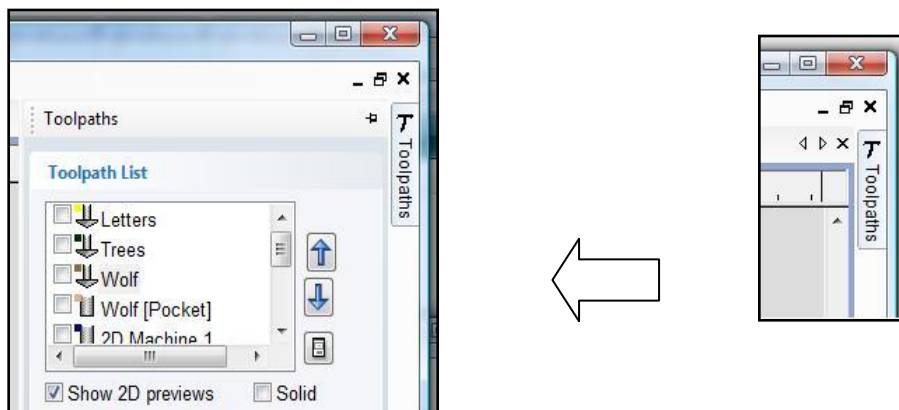

Click on the Toolpaths Tab to open the Toolpaths Window

Clicking on the Drawing or Toolpath tab will also close an open window.

Both windows have Auto Hide / Show behavior and can be locked open by clicking on the **Push-Pin button** in the top right corner of the window region as shown below.

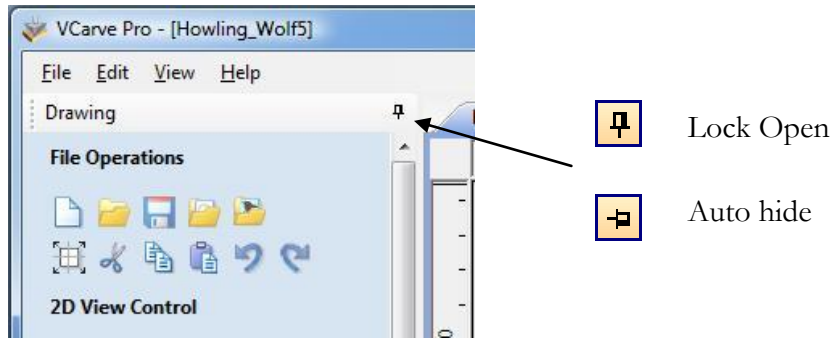





Auto Hide / Show windows

View Controls

The View Control options available when working in the 2D Design and 3D Preview windows are,





2D Design Window

	Zoom Interactive	Mouse with Middle Wheel – Push / Pull
	Zoom Box	Mouse without Middle Wheel – Shift + Push / Pull with Right Mouse button .
	Pan	Click top left corner Click bottom right corner Click and hold the Left mouse button – Esc to cancel
	Zoom Extents	Shortcut: Click and drag the Middle mouse button or if using a 2 button mouse, CTRL + drag with Right Mouse button .
	Zoom Selected	Zooms to show material limits in the 2D window Click to select an object or objects Zooms to the bounding box of the selections

Mouse with Middle Wheel can be used to interactively zoom in / out.

3D Window

	3D Twiddle	Click and drag Left mouse button in the 3D window
---	------------	--

□	Zoom	Right mouse button – Push / Pull
		Mouse with Middle Wheel – Rotate wheel
	Pan	Click and drag Right mouse button + Ctrl
□		Click and drag Right and Left mouse button
	Zoom to Fit	Zooms the whole 3D part to fit within the current 3D View window
	Isometric View	Shows the model in a 3D isometric view in the 3D window
	Plan View (Down Z)	Shows the top view of the model in the 3D View looking down the Z axis
	Side View (Down X)	Shows the side view of the model in the 3D View looking down the X axis
	Side View (Down Y)	Shows the side view of the model in the 3D View looking down the Y axis

Pressing **F2** & **F3** will toggle between displaying the **2D** & **3D windows**

File Operations - Setting up and managing the part

Overview

The first stage in any project is to create a new blank part or import some existing data to work with. At this stage a lot of parameters need to be defined relating to the size of the part and its position relative to the datum location on the CNC machine. Once the part has been defined and during the development process you may want to change the size of the material, import additional data and generally manage the project operation. In this section of the manual the initial creation of a part will be covered along with all the icons which appear under the File Operations section of the Drawing Tab:

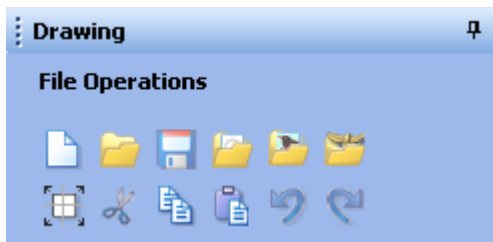

How to Start

When you first start the program you will see two Startup Task options on the left hand tab and also a list of your 4 most recently opened VCarve Pro parts as shown in the image below:

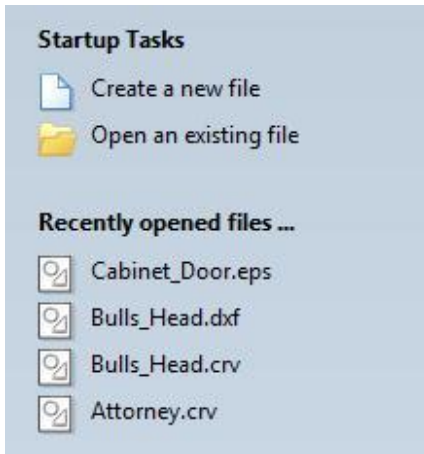

The first choice is whether you want to Create a new file or Open an existing one. Creating a new file allows you specify a size and location for a blank work area, set your material thickness and also set the model quality and even the shading color/material. The process to do this will be covered in the next section (File Operations) under the “New File” icon.

The second choice , “Open an Existing File” will allow you to open a pre-created file from your computer. This may be a file you previously created in VCarve Pro (*.crv) or a 2D vector layout from another CAD system (*.dxf, *.dwg, *.eps, *.ai and *.pdf). A CRV file will have the necessary information for material size etc. already embedded in it, the 2D formats will import the data at the size and position it was created, but will require you to go through the Job Setup form to verify/edit all the parameters for the part. This process will be covered in the next section (File Operations) under the “Open Existing File” section.

File Operations

In this section of the manual all the icons under the File Operations section of the Drawing Tab will be covered.

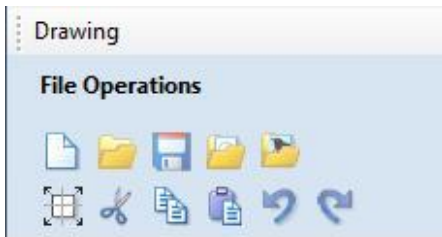

Create a New File This option opens the **Job Setup** form (below), which is used to create a new blank job of the width (X), height (Y), and thickness (Z) required. The relative origins for X0, Y0 and Z0 are also specified at this point, and the measurement units can be set in either inches or metric.

Job Setup Form Options

Size

Width

The material length along the X axis

Height

The material length along the Y axis

Material Z Zero

Indicates whether the tip of the tool is set off the surface of the material (as shown in the diagram) or off the bed / table of the machine for $Z = 0.0$.

Thickness

The material thickness along the Z axis

XY Origin Position

The X0, Y0 origin for the job on the CNC machine. This can be set at any corner or the middle of the job.

Use origin offset Moves the selected material origin relative to absolute X0, Y0.

Units

Defines the units of measurement that will be used, either inches (imperial/English) or mm (Metric).

In most cases a new job represents the size of the material the job will be machined into or at least an area of a larger piece of material which will contain the part which is going to be cut. Clicking **OK** creates a new empty job, which is drawn as a gray rectangle in the 2D Design window. Dotted horizontal and vertical purple lines are drawn in the 2D design window to show where the X0 and Y0 point is positioned.



Open File This option opens the File Open dialog window, allowing existing VCarve Pro files (CRV) and importable 2D vector files to be selected and opened.

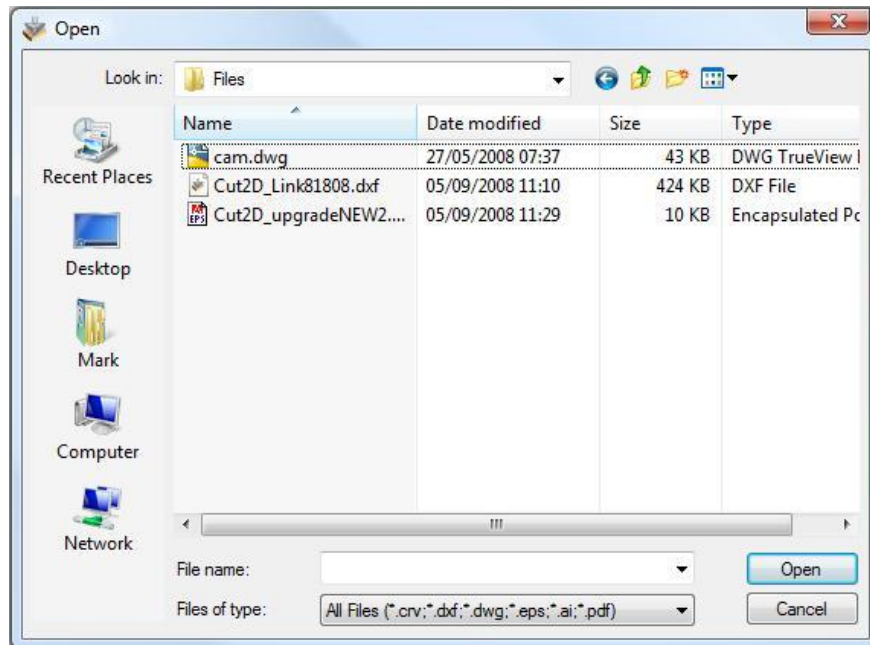

CRV Files previously created and saved in VCarve Pro will be opened and displayed in the 2D Design window. All calculated toolpaths are stored/opened from the CRV file.

DXF & DWG Files from other CAD or graphics software packages such as AutoCAD will be opened in the original size and position. The Job Setup Form is automatically opened showing the maximum X & Y dimensions of the opened design. The actual size of the material can then be specified along with the required thickness and appropriate X0, Y0 and Z0 origins.

EPS Files from typical design software such as Corel Draw can be opened. The Job Setup form will automatically be opened so the required material size can be specified. By default the EPS file will be placed with the lower left corner of the design at X0, Y0.

- AI Files from typical design software such as Adobe Illustrator and Corel Draw can be opened. The Job Setup form will automatically be opened so the required material size can be specified. The AI file will be placed with the lower left corner of the design at X0, Y0
- PDF Software such as the Adobe product range can be used to convert files from other design and word processing software into the industry standard PDF file format. The text and vector content of PDF files is extracted when imported into VCarve Pro. When importing multiple page PDF documents each page is placed on a separate layer.

Job Setup Form Options (for Open Existing File)

When an existing 2D data file is opened the same options are presented as for creating a New File except there are two additional settings under Data Scaling which are explained below. Refer back to the Create New File section for all the other options on the form.

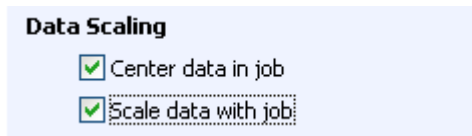

Data Scaling

Center data in job Checking this option automatically moves the vectors in the 2D file into the middle of the specified material block.

! Do not select this option if the job needs to stay in its original drawn position !

Scale data with job Checking this option automatically scales the vectors in the 2D file to fit the specified material block.

If one or both of these options are chosen, then as the Material Size is changed, then the vectors and any components will automatically be scaled or located as the size changes as per the selection.



Save File

This option opens the File Save As dialog window and allows the job to be saved as a .CRV VCarve Pro file. Navigate to the required folder, enter a suitable name for the job and click the **Save** button



Import Vectors

This opens the File Open dialog window and allows 2D DXF, EPS and AI and PDF files to be imported into the 2D View. The imported vectors will always be read in at the size and scale they were created in their original design software. Once open they can be scaled and edited in the same way as vectors created in VCarve Pro. All the Vector tools will be dealt with in that section of this manual. Toolpaths from PhotoVCarve and Cut3D can also be imported.

This opens the File Open dialog window and allows image files to be selected and imported into the current open job. File types - **BMP, JPG, TIF, GIF, PNG**



**Import
Bitmap**

Images are imported to trace/vectorize or sketch vectors over the top of them. This function will be covered in more detail in the 2D design section of this manual.

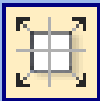

**Set Job
Dimensions and
origin**

This option allows the Job Setup form to be accessed for the current part. All the same options as were detailed in the Open New File section are available (material size, thickness, origin, scaling, units.)



Cut

The Cut tool removes the selected 2D objects from a design in a similar way to pressing the Delete key, but the selected objects are copied to the clipboard and can be Pasted into either the current file or a new file if required.



Copy

The Copy tool copies selected 2D objects to the clipboard, leaving the original in place and allows duplicates to be made and re-used in the design by pressing the Paste icon.



Paste

This Paste option places the contents of the clipboard (created by Cut or Copy) into the design, allowing elements to be re-used in different areas of a design or in other VCarve Pro parts.



Undo

Clicking this option steps backwards through the design changes made by the user.



Redo

Clicking this option steps forward through design steps that have been Undone using the Undo command (see above) to get back to stage that the user started using the Undo function.

This concludes the section on the File Operations area of the Drawing Tab.

2D Design and Management

Overview

The 2D View is used to design and manage the layout of your finished part. Different entities are used to allow the user to control items that are either strictly 2D or are 2D representations of objects in the 3D View. A list of these 2D View entities is described briefly below and more fully in later sections of this manual.

Ultimately the point of all these different types of objects is to allow you to create the toolpaths you need to cut the part you want on your CNC.

VCarve Pro has a Layer function for managing 2D data. The Layers are a way of associating different 2D entities together to allow the user to manage them more effectively. Layers will be described in detail later in the relevant section of this manual

Vectors

Vectors are lines, arcs and curves which can be as simple as a straight line or can make up complex 2D designs.

VCarve Pro contains a number of vector creation and editing tools which are covered in this manual. As well as creating vectors within the software many users will also import vectors from other design software such as Corel Draw or AutoCAD. VCarve Pro supports the following vector formats for import: *.dxf, *.dwg, *.eps, *.ai, and *.pdf. Once imported, the data can be editing and combined using the Vector Editing tools within the software.

Bitmaps

Although bitmap is a standard computer term for a pixel based image (such as a photo) in VCarve Pro it is used as a generic term for any of the supported types of raster (pixel) based images. VCarve Pro allows the following image file formats to be imported: *.bmp, *.jpg, *.gif, *.tif, *.png and *.jpeg. All these file types are images made up of tiny squares (pixels) which represent a scanned picture, digital photo or perhaps an image taken from the internet. In VCarve Pro there are two uses for these, one is to use it to fit a vector around specific colors in the image, the second is the ability to take an image and convert it into a 3D (texture). Both these functions will be covered in more detail later in this document. It should also be noted that many of the Vector Editing tools (Scale, Move, Rotate etc.) will also work on a selected Bitmap.

Vectors

Vectors have important uses in VCarve Pro, they describe the shape and boundaries of a part and the direction of a toolpath

As they are such an important part of two of the fundamental areas of the software there are a lot of tools to create, edit and manage them. In this section all these tools and vectors options will be briefly described. For practical examples of these tools you should review the tutorial videos.

Vector Import

Decorative vector designs and shapes will often be imported from another drawing package such as Corel Draw, AutoCAD etc. rather than being completely drawn in VCarve Pro. The Vector Import icon  is located in the File Operations area of the Drawing Tab. Once a vector has been imported then the imported vector shape(s) can be modified, moved, scaled, rotated, mirrored or deleted the same as vectors created within the software.

The following Vector file formats can imported into VCarve Pro.

DXF & DWG	Files from other CAD or graphics software packages such as AutoCAD will be opened in the original size and position. The Job Setup Form is automatically opened showing the maximum X & Y dimensions of the opened design. The actual size of the material can then be specified along with the required thickness and appropriate X0, Y0 and Z0 origins.
EPS	Files from typical design software such as Corel Draw can be opened. The Job Setup form will automatically be opened so the required material size can be specified. By default the EPS file will be placed with the lower left corner of the design at X0, Y0.
AI	Files from typical design software such as Adobe Illustrator and Corel Draw can be opened. The Job Setup form will automatically be opened so the required material size can be specified. The AI file will be placed with the lower left corner of the design at X0, Y0
PDF	Software such as the Adobe product range can be used to convert files from other design and word processing software into the industry standard PDF file format. The text and vector content of PDF files is extracted when imported into VCarve Pro. When importing multiple page PDF documents each page is placed on a separate layer.

NOTE: Any bitmap information in the PDF file is ignored.

While every endeavour is made to keep up with other software companies' changes in their file format it is possible that files in the above formats may not always be readable in VCarve Pro. In that case going back to the original design systems and saving the file in an earlier version may enable it to be loaded into VCarve Pro.





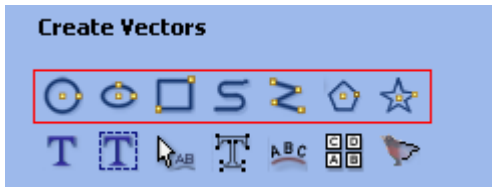

Creating Vectors

Simple shapes and designs can be drawn using the Circle, Oval, Rectangle and Polyline options. Shapes can be created by either entering exact dimensions in the Command Window or simply clicking the left mouse button in the 2D window to specify the parameters and coordinates dynamically by clicking/dragging with the mouse cursor. The first row of icons in the Create Vectors section of the Drawing Tab (highlighted with a red box in the image below) are all used to draw different types of vector shapes:



Here is a list of all the vector creation icons from the Create Vectors section of the menu:

Drawing Shapes

	Draw Circle	Circles can be created interactively with the cursor or by entering the exact coordinates and diameter/radius with typed input.
	Draw Ellipse	Ellipse / ovals can be created interactively with the cursor or by entering the exact coordinates for the center point, height and width with typed input.
	Draw Rectangle	Rectangles can be created interactively with the cursor or by entering the exact coordinates, type of corners (square, internal or external radius) and Width and Height using typed input.
	Draw Curve	This tool creates a smooth flowing continuous curve through clicked points. Simply move the cursor to the point where a point is required and click the left mouse button.
	Draw Polyline	This tool creates continuous straight lines through points clicked or entered coordinates. Move the cursor to the point where a point is required and click the left mouse button to create a new line. Or enter the appropriate XY position, distance or angle.
	Draw Polygon	Polygons (eg. Triangles, Pentagons, Hexagons etc.) can be created interactively with the cursor or by entering the number of sides, exact coordinates and radius using typed input.
	Draw Star	Stars can be created interactively with the cursor or by entering the number of points, exact coordinates and outer radius and inner radius percentage using typed input.

Each command gives you the option of dynamically drawing with the mouse cursor or entering precise data using the form. All these commands and the options within the form are covered in more detail in the Help File in the software - from the menu bar select Help and then Help Contents and click on the relevant part of the interface to jump to the Create Vectors section. In addition, vector drawing and manipulation is touched on throughout the video tutorials enclosed with the software.

The second row of icons under Create Vectors are mainly to do with Vector Text creation and manipulation plus the plate layout tool and the tool to trace vectors onto the colors in bitmap images. The image below shows these icons highlighted with a red box.

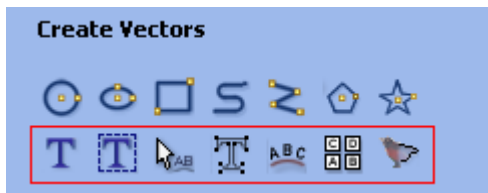

Creating Text



Draw Text

This option allows text to be created at any height using the units the model is being designed in (Inch or MM).

This option automatically sizes a block of text to fit inside the boundary box (width and height limits) of a selected vector or vectors. If no vectors are selected the text is scaled to fit the size of the material.



Draw Auto Text

When the Text form is open the Dimensions for the Width and Height of the selected vectors or job dimensions are shown, and these are used to constrain the font size of the text.



Text Selection

This tool must be selected in order to use the interactive Kerning and Line Spacing tools. The cursor changes to show the letter kerning and interactive arcing options are available.

In most cases all Text created in VCarve Pro can be VCarved, Engraved, Pocketed and Profile machined.



Convert text to Curves

Some fonts do occasionally include loops and problems that need fixing using the Node Editing tools before it can be utilized for other functions. This text first has to be converted to Curves, creating lines, arcs and bezier spans that can be interactively edited to fix the problem areas.

Script style fonts that are based on overlapping characters **can** be VCarved or Engraved without having to first convert the characters to curves.



Text on Curve

This tool creates requires the user to select a single line of text and a single vector curve/line. It will take the text and fit it onto the selected vector to follow the curvature. Options within the tool allow position, space and location against the line to be edited.

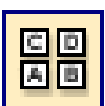

Plate Production

This option is for designing and engraving multiple badges or nameplates using variables for positioning imported data from a text file list. The production plate functionality is typically used by engravers making badges from a database file supplied by a customer, but could also be useful for making nameplates for

hotel rooms with consecutive numbering. This function cannot be used with 3D Data or 3D toolpaths.

This tool automatically traces or fits vectors to image files so they can be machined. Import and select an image in the 2D view, then open Fit Vectors to Bitmap.



Fit Vectors to Bitmap

After importing an image the Tracing option allows vector boundaries to be created automatically around regions in the image.

Images can be traced either in colour or black and white mode.

All these commands and the options within the forms are covered in more detail in the Help File in the software (from the menu bar select **Help** and then **Help Contents** and click on the relevant part of the interface to jump to the Create Vectors section). In addition vector drawing will be touched on throughout the video tutorials enclosed with the software.

Vector Editing

Once vectors have been created within VCarve Pro or have been imported from other design software packages you may want to make changes to them. These changes may be to prepare for machining or for use as construction vectors for making 3D shapes using the Modelling Tools. There are a number of functions for editing vectors which will be covered in this section of the manual. All the icons under the Edit Vectors section of the Drawing Tab will be referenced along with the icons under the Align Objects section of the menu.

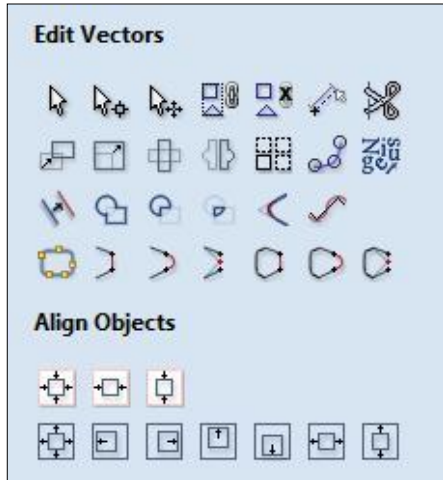

As previously stated the Help File within the software should be consulted for more in depth descriptions of the functions and their options.

Editing Modes

From the 2D view a vector can be selected and then 3 different editing modes allow different dynamic edits to be made to the vector(s) depending on which option is selected from the Edit Vectors section.

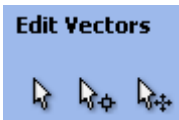

The three editing modes are; Vector Selection, Node Editing and Interactive Selection. By default the software is normally in the Vector Selection mode.

Vector Selection Mode



Vector Selection Tool

Selected from Edit Vectors section

When the Vector Selection Tool is chosen, the selected vectors are shown as dotted purple lines. Vectors need to be selected before any of the editing tools such as scaling and moving etc. can be used.

Vector selection methods

Multiple vectors can be selected in the following **4 ways**.

1. Manual multiple selection

Hold down the **Shift** key while clicking the **Left** mouse button on each vector required.

Objects can be deselected by simply clicking on the object again with the **Shift** key pressed.

Moving the cursor from Left to Right selects only FULLY enclosed objects.

Click and drag the left mouse button moving from **Left to Right** selects all objects fully inside the selection rectangle.

Moving the cursor from **Right to Left** selects all objects **INSIDE** the selection rectangle and also any objects that the selection rectangle **TOUCHES**.

Click and drag the left mouse button moving from Right to Left selects all objects inside the selection rectangle + any that the selection touches.

2. Pressing the keyboard keys **Ctrl + A** will select all vector objects in the design

Selected vectors are displayed as dotted purple lines.

Vector deselect

Selections can be cancelled by simply,

1. Left clicking on an area outside the selection
2. Pressing the Escape key
3. Pressing the **Right mouse button** and selecting **Unselect All** (top option) from the list. You must click on the white drawing background to get this option in the menu.

Node Editing Mode



Node Editing Tool

The Node Editing tool can be selected from the Editing window or by pressing the Keyboard shortcut **N** to toggle between Selection and Node Editing modes.

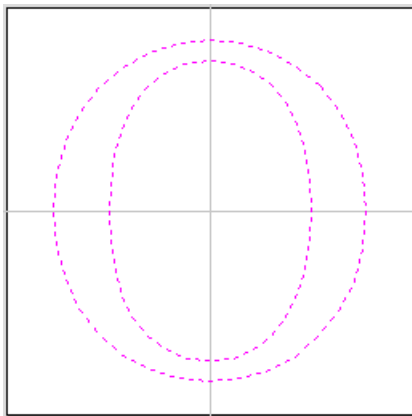

Vectors selected

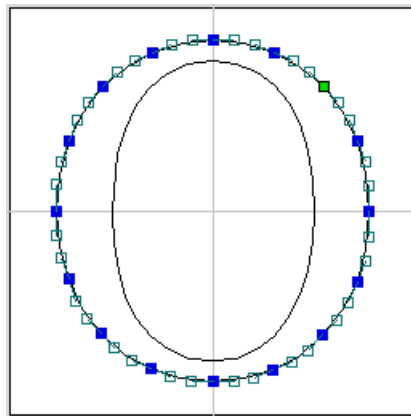

Bezier node editing

When the Node Editing tool is active the cursor changes to a Black Arrow indicating that individual points (nodes) can be edited. Nodes can be interactively moved by clicking and dragging the left mouse button on a node to select and move the node to a new position.

The shape of lines, arcs and Bezier (curve) spans can be edited by clicking and dragging on the nodes or control points to move them. Multiple nodes and control points can be selected and moved by using the multiple selection options such as the Shift key and dragging to make a selection.

If you right click on nodes or spans a context sensitive popup menu will be displayed which allows you to insert or delete points and nodes, cut the vector, move the start point etc.

Node editing vectors is a very powerful way to be able to make changes to the vectors in your part. The node editing options are covered in a lot of detail in the Help Contents section of VCarve Pro's Help file.

Interactive Selection Mode



Interactive Selection

The Interactive Move, Scale, Rotate Selection tool is used to quickly and easily modify designs using the mouse in the 2D view. When using this tool any selected vectors are displayed with handles that can be used to interactively move, scale and rotate the vectors.

Clicking twice on one of the selected objects and the interactive scaling, movement and rotation handles are displayed in the same way as selecting this icon. Lines, arcs and bezier spans will be displayed as **Dotted Magenta Lines** and Text and Grouped objects will be displayed as **Solid Magenta lines** as in the image shown below.



When in this mode the mouse is used to click on one of the handles which has appeared on the selected Vector/s. Each handle is used for a specific editing operation as detailed here:

Handle	Operation	Additional options
White Middle box	Move the selected objects	Hold Shift for linear X or Y moves
White Corner boxes	Scaling proportionally	Hold Shift for scale from middle
Black Corner boxes	Rotating dynamically	Hold Shift 15 degree increments
White Middle boxes	Scaling non-proportionally	Hold Shift for symmetrical scale

You can deselect objects by clicking on the white background area, unless the Shift key is pressed. Objects can also be deselected by pressing the Esc key or click Right mouse > Unselect All.

Group and Measure

The icons to Group and Ungroup vectors and for Measurement/Inspection are located under the Edit Vectors section of the Drawing Tab as shown highlighted with a red box in the image shown below.

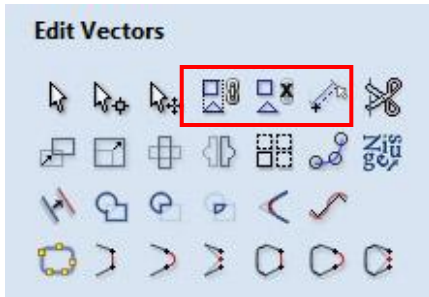

Group Vectors

Vectors can be **Grouped** allowing any number of vectors to be included as a single object that can easily be selected, moved and scaled etc. ShortCut key for this operation is CTRL + G.

Grouping vectors is particularly useful for machining purposes, where different vectors will be used for a single toolpath operation. Clicking any member of the group will select the entire group.



Ungroup Vectors

Ungroups a set of Grouped vectors back to its individual vectors before it was grouped. ShortCut key for this operation is CTRL+U.

The interactive Measuring Tool is used in the 2D view to check the size and position of objects.

The default mode is to **Measure Between 2 Points**. Place the cursor at the point to start measuring from and click the Left mouse button

Move the cursor to the point to measure to and click Left mouse button.



Measure/Inspect

Selecting the second option calculates the following properties for the currently selected vector

Selection type - Line, Arc, Bezier

Length, Start and End coordinates

Radius and Center Point

The trimming tool allows the user to just click on sections of vectors they want to delete.

The program finds the closest intersections either side of the clicked portion of the vector and removes the piece of the vector between the intersections. Optionally, when the form for this command is closed, the program can rejoin all the remaining trimmed pieces automatically. This has been the most requested enhancement for the design tools in the program.



Trim Vectors

Without using this tool, to remove an overlapping section of a vector, the user would need to insert extra nodes into both vectors, manually delete the intermediate sections and then manually join the resulting pieces. These operations can be performed with a single click using this tool.

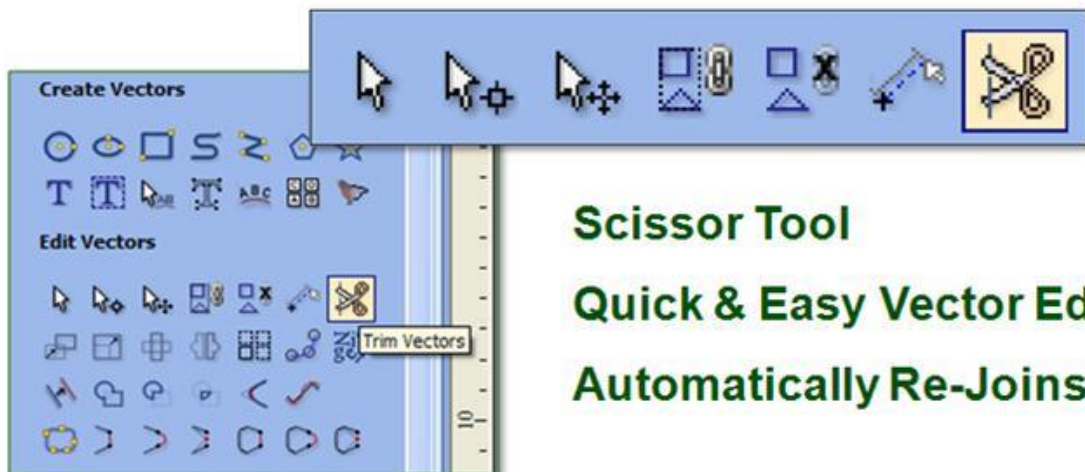

Scissor Tool

Quick & Easy Vector Editing

Automatically Re-Joins

When the tool is selected the cursor changes into a 'closed' scissor shape. When the cursor is moved over a vector suitable for trimming the scissors 'open' to show you can click and trim.

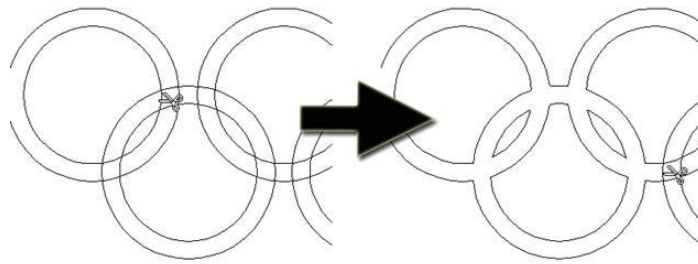

When the trim tool is selected the following form is displayed ...

 **Trim Vectors**

To trim overlapping vectors click on sections of vectors you want to delete.

To delete closed non-overlapping vectors hold down the Shift key when clicking.

Rejoin trimmed sections automatically when form is closed.

Close

The only option on the form allows the user to select whether the program will automatically try to rejoin trimmed vectors when the form is closed. For most simple cases like that shown above with the overlapping rings, this option can be left checked. If you have an example where for instance many trimmed lines meet at the same point, you may want to uncheck this option and rejoin the vectors manually.

Move, Scale, Rotate, Mirror and Duplicate

The icons to move, scale, rotate, mirror and make copies of different items are located under the Edit Vectors section of the Drawing Tab as shown highlighted with a red box in the image shown below:

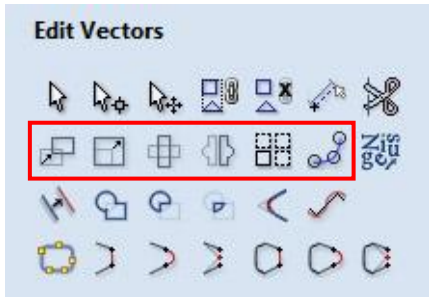

These are a very important set of tools as even though they are in the Edit Vectors section of the menu they can also be used to manipulate imported Bitmap images and also the Grayscale toolpath previews. As with all the icons listed in this manual more expansive descriptions and examples can be found in the Help File under the Help drop down menu – Help Contents.

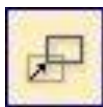

Move

Selected vectors/bitmaps/grayscale-toolpath previews can be accurately moved and positioned using this option.



Set Size

Selected vectors/bitmaps can be accurately scaled to an exact size using this option.



Rotate

Selected vectors/bitmaps/grayscale-toolpath previews can be rotated to a new orientation using this option.



Mirror

Selected vectors/bitmaps can be mirrored to a new orientation using this option.



Block Copy

Multiple copies of vectors/bitmaps can quickly be created using the Copy Vectors in a Linear or Circular Array.



Copy Along Vectors

Selected vectors/bitmaps can be Copied Along Curves.

Select the item to copy along the curve and holding the Shift key select the vector curve or curves to paste the item along.

Nesting

The Nesting tool will automatically fit vector shapes within the user defined area in the most efficient way it can calculate (based on the user defined parameters). By default the area the vectors will be fitted is the current **Job Size** but it is also possible to select a vector as the nesting area. This is a powerful way to optimize material usage and increase toolpath efficiency when laying out and cutting a number of shapes. The image below left show a set of letters which have been typed out using the normal **Text** layout tool, the image on the right shows the same set of letters after the **Nest Vectors** function has been used to optimize their layout. The **Nest Vectors** tool will be documented in detail in this section to show how the options within the menu control the layout.



IMPORTANT NOTE: What kind of yield should I expect from the Nest Vectors command?

While the **Nest Vectors** function within VCarve Pro is designed to do as good a job as possible it is important to understand it will not always nest parts as well as an intelligent (and patient) human. The nesting in VCarve Pro works incrementally and does not re-arrange parts it has already placed. Therefore it does not have the ability to adjust things as the parts are being fitted that a human nester might see could be more efficient.

The **Nest Vectors** function excels when the parts are relatively small compared to the nesting area and there are a large number of parts to nest.

If you have a relatively small number of shapes to nest or you plan to cut the same set of parts many times then it may be better to take the time to manually nest your vectors. When you use the **Nest Vectors** function and see some obvious places that you could do better this is a good indicator that manual placement may be better.

IMPORTANT NOTE: Sheets

The amount of material required to **Nest** the selected vectors may be larger than the specified work area (**Job Setup**). To cope with any “overflow” VCarve Pro makes use of a new type of entity called **Sheets**. **Sheets** are used for any nested shapes that will not fit within the boundaries of the specified **Job Size** (or the selected vector). Additional **Sheets** will be created using the same parameters chosen to **Nest** the vectors. These are displayed to the right and above the current Job area as can be seen in the image shown below. The use of the Sheets will be explained in more detail in section below on choosing the **Active Sheet** within the **Nest Vectors** form.

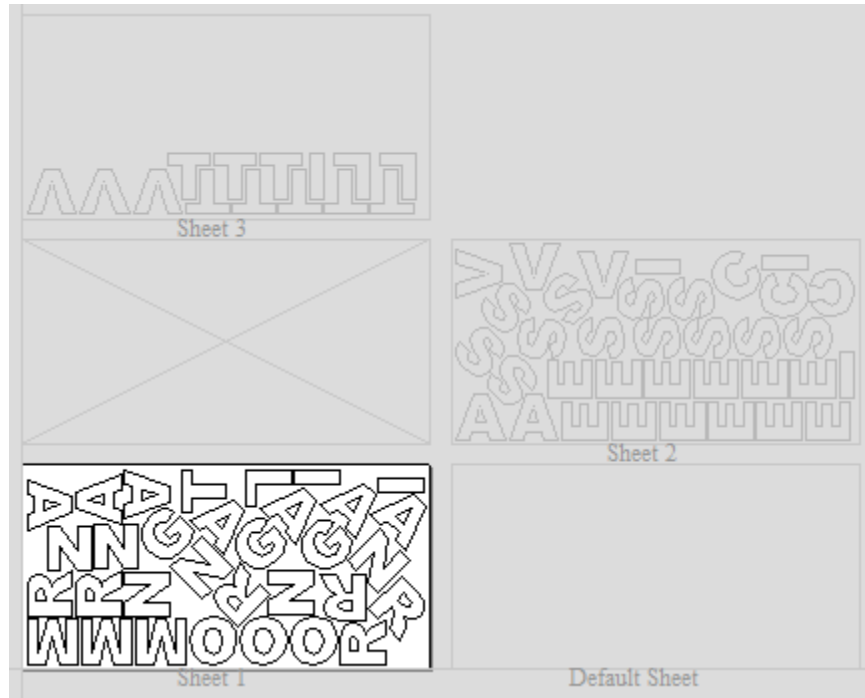

The concept of **Sheets** is very specifically related to machining the finished parts and is not designed to replace layers. **Sheets** should **NOT** be used to organize vectors for modelling or to organize vectors which you intend to use for different machining operations, in those cases the **Layers** should be used to manage the vectors.

The sole purpose of **Sheets** is to allow nested parts for production type machining to be laid across many units of the same material. Only vectors on the **Default Sheet** can be nested so **Nest Vectors** should be the last command carried out on the parts before machining. As such objects should not be nested more than once, if you do not like the nesting solution then you should use the **Undo (Ctrl + Z)** command immediately and then make changes to the settings before trying the nesting again.

How VCarve Pro Nests Vectors

Nesting shapes is a complex calculation which requires the user to make sure the vectors are in the correct state to get the results they are looking for, this is especially important when nesting overlapping vectors or designs that have sets of vectors that need to stay in position with each other. In certain situations it is necessary to group together particular vectors to get the correct result. For simple shapes within shapes such as an “O”, “B”, “P” etc. there is no need to group them before nesting. VCarve Pro will keep these internal shapes in the correct position and orientation as the shapes are nested.

If the 'outer' vectors of the items being nested are overlapping (and are supposed to be overlapping) then they should be grouped together. This will ensure that the software does not try and nest other items in incorrect places inside of these objects or break the components apart; the nesting for these groups will be done using the bounding box of all these grouped items.

Below you can see an example showing the value of this. The first image shows 3 parts to be nested 6 times each, they include overlapping vectors and single lines. The second image shows the parts nested **WITHOUT** Grouping as you can see the parts are split apart and the single lines are deleted. The 3rd image shows the parts **Grouped** before nesting into 3 specific groups, these keep all the parts in the correct position and does not delete the individual lines.

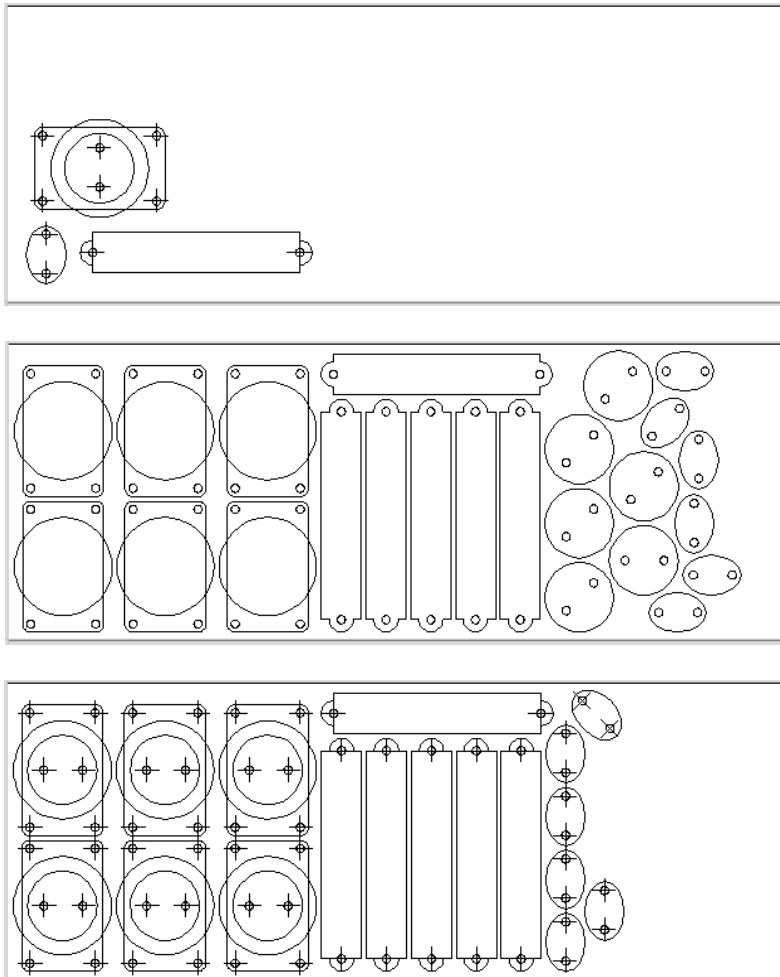

Original vector layers for grouped vectors will be remembered even if the vectors are nested. If nested and then ungrouped the objects within them will go back onto their original layers. This can be useful if you have arrangements of production parts which are on different layers that you need to nest. These might be parts which use layers for different machining operations (drilling, pockets etc.). To nest these you can do the following:

- 1 Group the complex component represented by vectors on different layers.
- 2 Nest the grouped objects to optimize placement.
- 3 Select all the vectors and Ungroup to get the data back on the original layers for machining.

Once you click the icon you will see the form shown below. You can see there are a lot of options on this particular form, these will all have a bearing on how the parts are nested. Generally it is assumed that you are nesting parts for the purposes of machining so a number of the options are set in regard to the tooling you plan to use and parameters associated with cutting the parts out. It is therefore very important to use the correct values that correspond to the machining choices you plan to make and keep a note of these so you use the correct values when you come to actually create the toolpaths.

Zigzag Nest Vectors

Tool and Clearance Settings

 Tool Dia. (D) inches
Clearance (C) inches
Border Gap inches

Part Nesting Options

Rotate parts to find best fit
Rotation step angle °

Mirror parts to find best fit
 Allow parts inside other parts

Sheet Options

Nest from ...

Nest Direction
 Along X Along Y

First vector is nest boundary

Individual Part Properties

Number of copies

Active Sheet

Tool and Clearance Settings

The settings in this section of the form will determine the spacing which will be left between each of the nested vectors and also control how close they are to the edge of your nesting area.

Tool Dia. (D)

Enter the diameter of the tool that you will be using to **Profile** (cut-out) the vectors you are nesting. This is the minimum distance that will be left between shapes once they are nested.

Clearance (C)

The **Clearance** value will be combined with the specified **Tool Diameter** to create the final minimum spacing between the nested shapes. For example a **Clearance** of 0.05" combined with a **Tool Diameter** of 0.25" would create a minimum spacing gap of 0.3" ($0.05 + 0.25 = 0.3$).

It is important to note that if you want actual material to be left between the nested shapes once they are cut out that the **Clearance** needs to be larger than the diameter of the tool. In the example used above where the minimum gap is 0.3" ($0.05 + 0.25$) the area machined by a 0.25" diameter tool cutting these shapes out would overlap as shown in the image to the left below (the blue shows the area which would be removed by the tool), this would leave no material between some of the parts. If you wanted there to be material between the cut-out passes then you would need to specify a **Clearance** value larger than the **Tool Diameter**. For instance a **Clearance** of 0.3" would make a total gap of 0.55", this is shown in the image below right. This would leave a minimum of 0.05 inches of material that would be left once the tool had cut out the shapes. This would be very important if using tabs to hold your parts in place, or if you wanted to prevent the scrap from potentially jumping off the table.

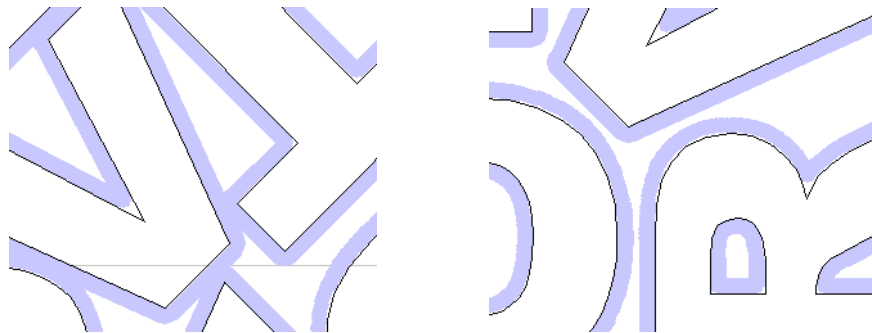

Border Gap

The **Border Gap** value is applied to the edge of the area which is being used to nest the vectors into. It will be added to the **Clearance** value around the edge of this shape to create the minimum distance that parts will be nested in respect to the nesting boundary.

Vectors can be nested either within the whole Job area or into another selected vector (see section below on **First vector is nest boundary** for more information on that option). The shapes will be nested as close to the edge as possible using the **Clearance** specified to determine the minimum distance from the edge. In many situations it is beneficial to have an extra gap from the edge of the material to ensure that the tool does not overlap into an area where there may be clamps (or other obstacles) and to ensure that some material is left for hold-down. The **Border Gap** can be used to define this extra distance. In many cases it would be defined as the tool

diameter or an even larger value. Below left the image shows no **Border Gap**, below right you can see a **Border Gap** has been defined leaving a boundary area around the edge of the nesting area.

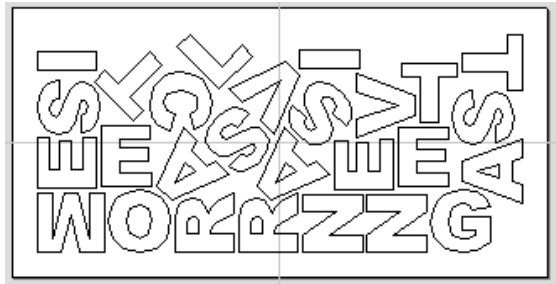
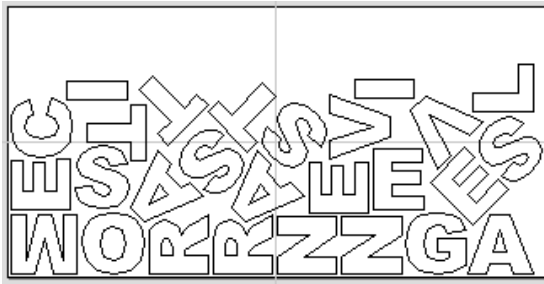

Part Nesting Options

The options in this area of the form will all directly affect how many parts or how efficiently it is possible for the software to fit shapes into the defined nesting area. The use of these options may depend on the particular material and application you are going to be using your cut parts for. Think carefully about the effect they will have on your shapes to ensure it does not adversely affect the finished cut parts.

Rotate Parts to find best fit

Checking this option will allow the software to rotate the selected vectors in order to try and better fit them. The increments of rotation the software will use is based on the **Rotation step angle** which is defined in the form area shown below.

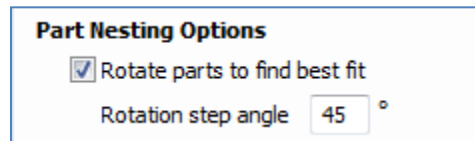

Part Nesting Options
 Rotate parts to find best fit
Rotation step angle °

In theory the smaller the specified angle the more options the software will have to fit the shapes together so the more efficient the nesting will be. This does depend on the shape of the vectors though. It should also be noted that the smaller the angle specified the longer the nesting will take to calculate.

Un-checking this option will ensure the parts keep the same orientation that they had when selected. This could be important if you are working with shapes that need to be oriented in a specific direction, for instance in regard to the material grain.



The image above and left shows the letters nested with 30 degree rotation and the image above right shows the same letters nested with NO rotation. As you can see by allowing the rotation the software can fit the letters into a smaller area. In this case it is not a huge difference but the more shapes there are and depending on the style of the shapes it could be a bigger margin.

Mirror parts to find best fit

Checking this option will allow the nesting to mirror (flip) the vectors in order to try and more efficiently nest the selected shapes. This should only be checked if the direction the parts are cut in is not important. For instance if you are using pre-finished material you would always want the face of the part to the top of the material and so would not want to allow the software to mirror them. If the parts were being cut-out and then finished or depending on the material being cut this may not be an issue and so could be used to help fit more parts into the nesting area.

Allow parts inside other parts

Checking this option will allow the software to nest within the internal areas of shapes that have gaps in the middle. This would be a good way to optimize material if you were cutting out parts but would not be a good choice if the inside of the shapes was only going to be pocketed as it would not then be scrap material. **Grouped** objects will not allow shapes to be nested within them even if they appear to have space to fit the smaller items. They would need to be ungrouped to allow the software to use the internal regions. Standard typed text will allow nesting on inside areas as shown in the example below.

In the two images below you can see a set of letters which are going to be cut out. The larger letters have sizable internal areas that will become wasted scrap, using the **Allow parts inside other parts** option means that VCarve Pro will use these internal areas to fit any smaller parts into them. This can be seen in the right hand image which shows the letters after nesting, where the inside of the O's and the B have been used to nest the smaller shapes.

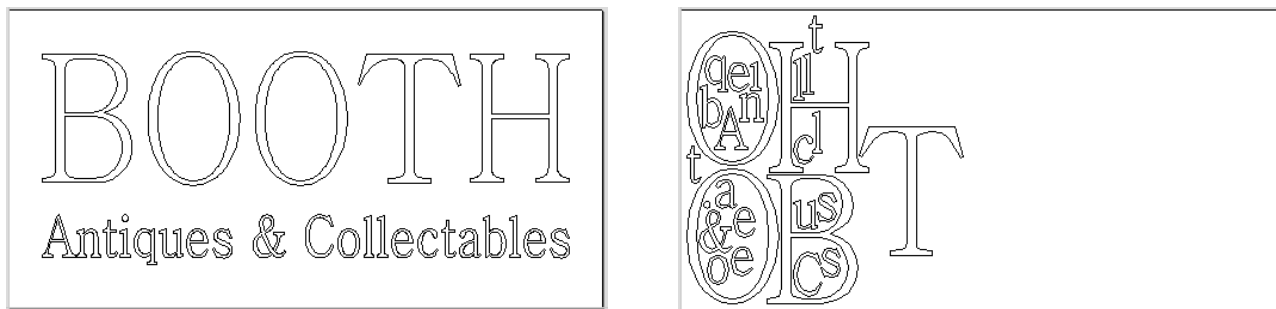

Sheet Options

Nest From

This area of the form is used to define which corner the nesting will start in. There are four options which can be selected from the options in the form shown in the image below:

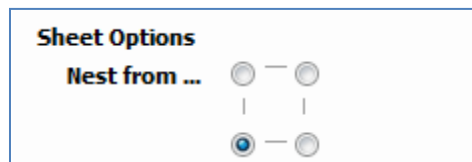

Each node corresponds to the respective corner of the Material or the selected boundary vector. The first nested parts will be placed in that corner and the shapes fitted according to the **Nest Direction** specified (see section below).

Nest Direction

The options in this area of the form are used to select how the parts will progress as they are positioned within the sheet. The best way to think of this (for the purposes of this section) is that they “pour” out of the selected corner filling the sheet in one axis then advancing along the other defined axis (X or Y)

Along X

Checking this option means the nested vectors will fill the boundary area vertically then progress horizontally along the X axis, radiating from the corner selected in the **Nest From** section of the form. The image below shows the **Along X** nesting option with **Nest from...** set to the lower left corner.

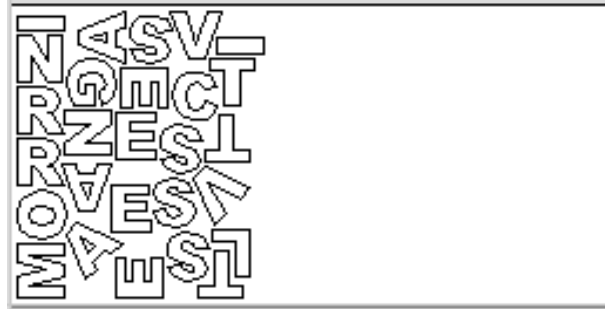

Along Y

Checking this option means the nested vectors will fill the boundary area horizontally then progress vertically along the Y axis, radiating from the corner selected in the **Nest From** section of the form. The image below shows the **Along Y** nesting option with **Nest from...** set to the lower left corner.



First vector is nest boundary

Checking this option means the first vector selected as will be used as the boundary for the nesting area. This can be useful if you need to define a non-rectangular shape to nest vectors into, such as large off-cut from a previous job. It's important to note that using this option will not respect the currently defined **Job Area** if the selected boundary vectors goes outside of it. If there are too many vectors to fit into the first selected vector then additional **Sheets** will be created using the same boundary shape for the parts being nested, the boundary vector will be positioned on the **Default Sheet** (zero) along with any items not selected for nesting.

Not having the **First vector is nest boundary** option checked means all the selected vectors are nested into the whole of the defined Job Area (defined by the **Job Setup** form accessed from 'Edit – Job Size and Position' from the menu bar).

IMPORTANT NOTE: Using a grouped vector as the nest boundary

If you need to represent a sheet with holes or other features which can't be represented with a single selected vector as the new boundary it is possible to also use a Grouped vector for the first selected item then the shapes will be nested within the spaces in this.

Individual Part Properties

This function is very useful if you have a number of the same part to make and need to nest many parts at once. It allows multiple copies of the selected object/s to be nested without making the copies prior to the operation.

If you want more than one incidence of a particular item then select it from the 2D view. In the box where it says **Number of Copies** enter however many copies you want and hit **Apply** the selected vectors will be marked with a green number indicating how many copies of that item will be made when they are nested. Different shapes or groups of shapes can be assigned different numbers of copies. To stop an item being copied multiple times just set the **Number of Copies** back to **1** and hit **Apply**.

Active Sheet

This option lets you choose which **Sheet** of vectors is currently active, either for editing or applying toolpaths onto.

The **Active Sheet** can also be chosen when the **Nest Vectors** form is not open by using the drop down option from the base of the **Drawing** menu – this is shown in the image below left highlighted with a red box, the image below right shows the drop-down with the choice of currently available **Sheets**.



Offset, Weld, Fillet and Curve Fit

The icons to offset, weld, fillet and Curve Fit vectors are located under the Edit Vectors section of the Drawing Tab as shown highlighted with a red box in the image shown below:

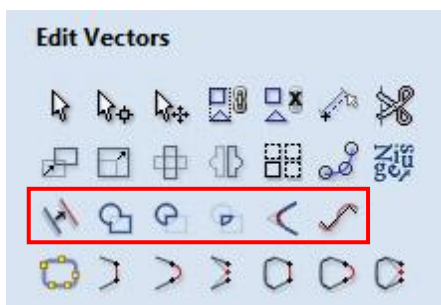

These functions only work with vectors and do not operate on other entities. As with all the icons listed in this manual more expansive descriptions and examples can be found in the Help File under the Help drop down menu – Help Contents.



Offset Vectors

Selected vectors (open or closed) can be offset either inwards or outwards to create new vector shapes that might be useful for edge patterns or borders etc.



Weld Vectors

Welds overlapping vectors together to create a new shape which follows the outermost edge of all the selected shapes.



Subtract Vectors

Welds overlapping vectors together to create a new shape which subtracts the subsequent selected vectors from the first one selected.



Union Vectors

Welds overlapping vectors together to create a new shape which is a union of all the overlapping vectors.



Create Fillets

Fillets radiuses can be added interactively at points where 2 straight vector lines meet.

The Fillet tool only works with straight lines - not beziers or arcs.

Clicking this will open the Create Fillets form shown below.

< **Create Fillets**

Fillet / Tool Radius: inches

Click on an angled corner to change corner into a circular fillet

Fillet Type

Normal fillet

'Dog-Bone' Fillet

'T-Bone' Fillet

“Bone” Fillet Options

These options allow 2 special types of filleting for straight line vector corners. They will create an overcut shaped area in corners to allow clearance for another piece of material to be slotted into the part without being obstructed by material left by the radius of the tool. Below left you can see a blue piece of material fitted into a normally cut slot, this would fit no further in than the radius of the tool would allow. Below right you can see the same situation with a slot which has the “Dog-Bone” style corners applied to it which allows the part to fit full depth into the slot.

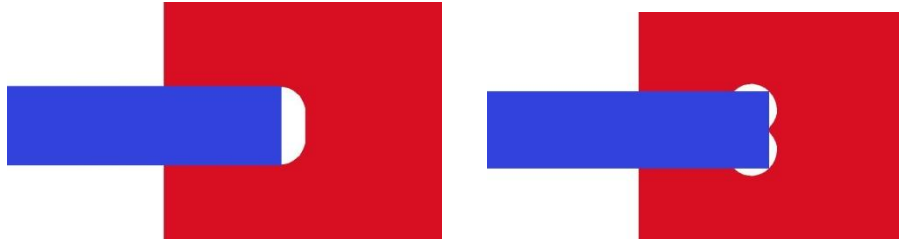

This is a very useful tool for slot-together furniture designs, model aircraft, dinosaurs etc. Below you can see a part from a slot together dinosaur on the left is the standard part and on the right is the same part with the “T-Bone” style fillets added to these slots. This type of fillet needs to be used when the slot is close in size to the tool diameter.

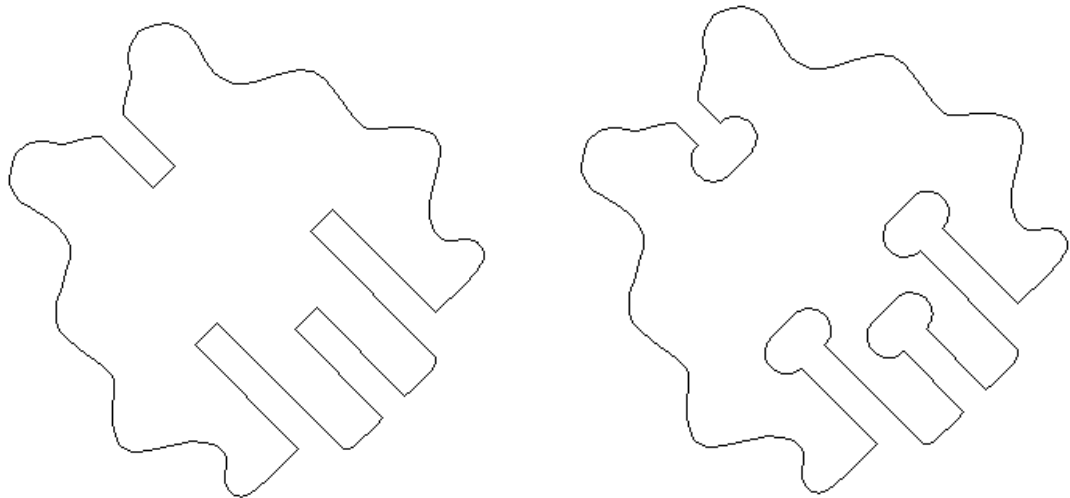

Fillet / Tool Radius

This size of this value is used to create the fillet as described for each individual type of fillet below. To create any of these Fillets you need select the type required then move the mouse cursor so it is over a corner between two straight lines, if it is a legitimate place to create the fillet then a check mark will show and the user can click the mouse button to create it. It should be noted that this will not fillet arcs or Beziers even if one of sides of the node is a line.

Fillet Type

Normal fillet

This creates a standard corner fillet based on the **Radius** defined, typically this would be used for design purposes rather than editing a slot for fitting purposes. The images below are used more as a way of comparing this type with the other two new options. Below left is the vector before filleting the two inside radii, on the right is the filleted version.



'Dog-Bone' Fillet

This creates a circular cut-out style of fillet, the circles will be placed so the upper right part of the circle touches the original sharp corner and are created with the **Radius** specified. This option should not be used if the slot width and the tool are similar in size. Below left is the vector showing the slot before filleting, on the right is the filleted version using the **'Dog-Bone'** option.



'T-Bone' Fillet

This creates a circular cut-out style of fillet, the circles will be placed so the right hand node of the circle touches the original sharp corner and are created with the **Radius** specified. This option should be used if the slot width and the tool are similar in size so the slot can “grow” out to the side to ensure there is space for them to fit. Below left is the vector showing the slot before filleting, on the right is the filleted version using the **'T-Bone'** option.



The placement of the fillet is an interactive process; you can choose which side of the 'corner' the T-bone fillet is placed.

If you click on a 'corner' the fillet will be placed automatically on the longest side. By clicking to the side of the corner you want the fillet placed you can choose which side the fillet is placed on ...

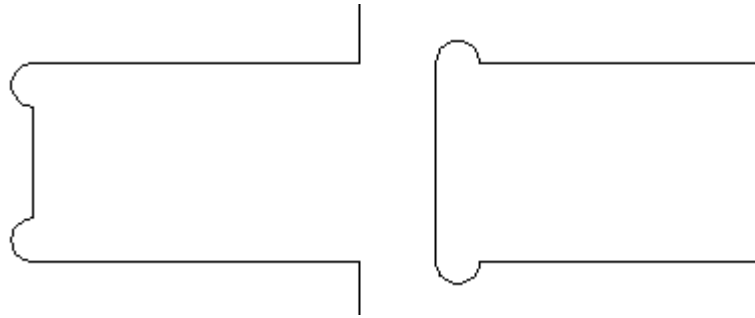

In addition, fillet arcs can be removed by simply clicking on an existing fillet arc. This works even for vectors that have been imported with filleted corners. This feature allows the user to easily change the size of fillets by clicking once to remove the existing arc and then clicking the corner to insert the new fillet.

In many cases, by allowing the user to control which side of the corner the 'T-Bone' fillet is placed on means that the fillet can be hidden when the pieces are assembled.



Fit Curves to Vectors

Fit curves to selected vectors.

Either lines, arcs or beziers are fitted to selected data.

This function allows the user to fit arc, Bezier curves or straight lines to selected vectors. The newly created vectors will be approximated based on a user defined tolerance. Using this function can aid with smoothness for some toolpath options and also help to simplify data for modelling purposes. The **Curve Fitting** function can be accessed from the **Edit Vectors** area of the **Drawing** menu as shown highlighted with a red box in the image below or by using the short-cut-key combination “**Ctrl + F**”.

Either of these methods will bring up the following form:

Fit Curves to Vectors

Fitting Type ...

Circular Arcs

Bezier Curves

Straight Lines

Tolerance: 0.005 inches

Keep sharp corners

Max. Angle 60.0 degrees

Replace selected vectors

Curve Fit Close

Fitting Type...

Circular Arcs

Checking this option means the selected vectors will be approximated using arcs. Below left is the vector before fitting, below right the same vector fitted with arcs.

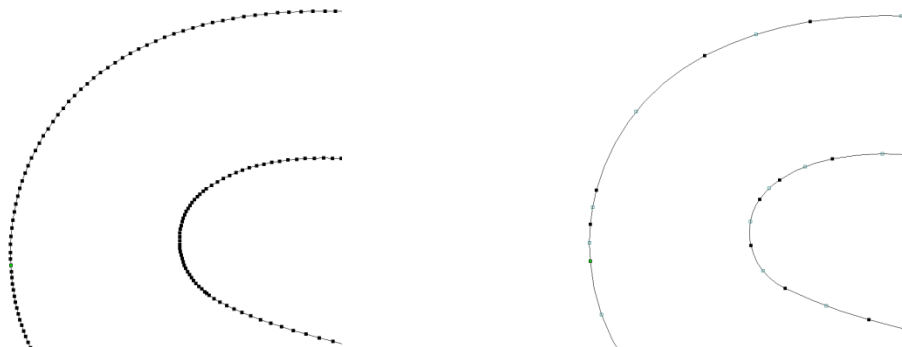

Bezier Curves

Checking this option means the selected vectors will be approximated using Bezier curves. Below left is the vector before fitting, below right the same vector fitted with Bezier spans.

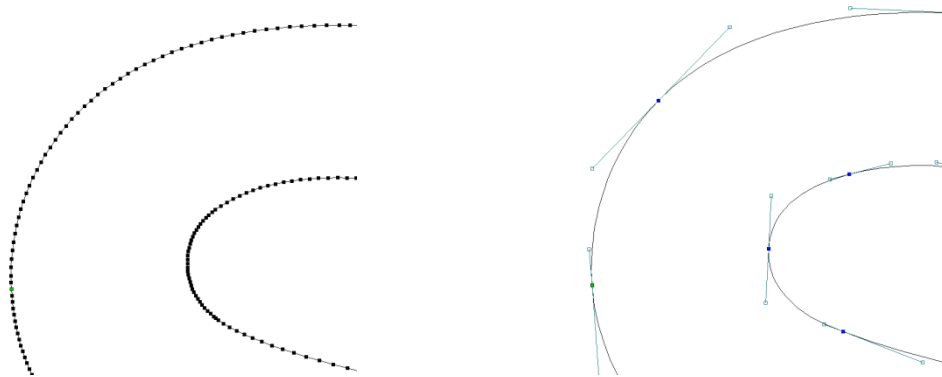

Straight Lines

Checking this option means the selected vectors will be approximated using straight lines. Below left is the vector before fitting, below right the same vector fitted with straight lines.

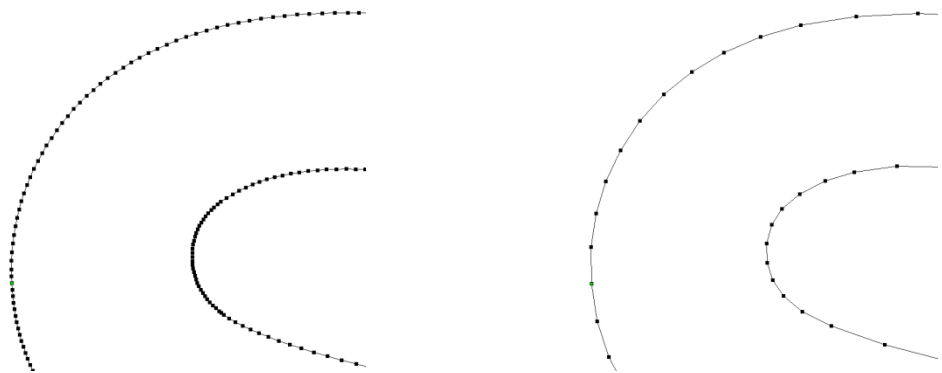

Tolerance:

The value which is set in the **Tolerance** area determines how closely the original vectors will be approximated. The newly created, **Arcs**, **Beziers** or **Lines** will be generated within a distance of the original vector which is plus or minus the specified **Tolerance** value. The smaller the value the closer to the original the new data will be but it will also mean more data points will be used. A larger **Tolerance** will not be as accurate to the original but will have less data points. The diagram below shows the curve fitted to two straight lines with the max possible distance between them defined by the **Tolerance** set.

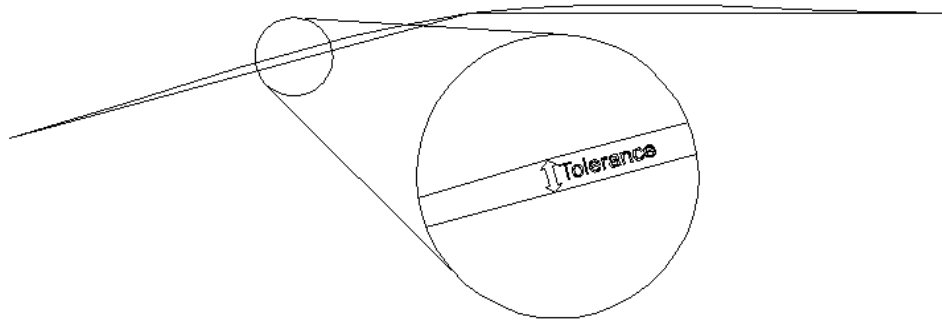

Keep Sharp Corners

Checking this option will make the **Curve Fitting** routine keep sharp corners which have a difference greater than the **Max Angle** value specified. Any corners where the difference in angle is less than this value will be modified within the specified tolerance. The images shown below demonstrate how this works. The first image shows a set of straight lines before curve fitting with the angles shown between the spans. The second image shows this after curve fitting with the **Keep sharp corners** set with a value of 20 degrees. You can see the two lines which were under 20 degrees difference have had a curve fitted between them but the other corner has been retained as the angle is greater than 20 degrees.

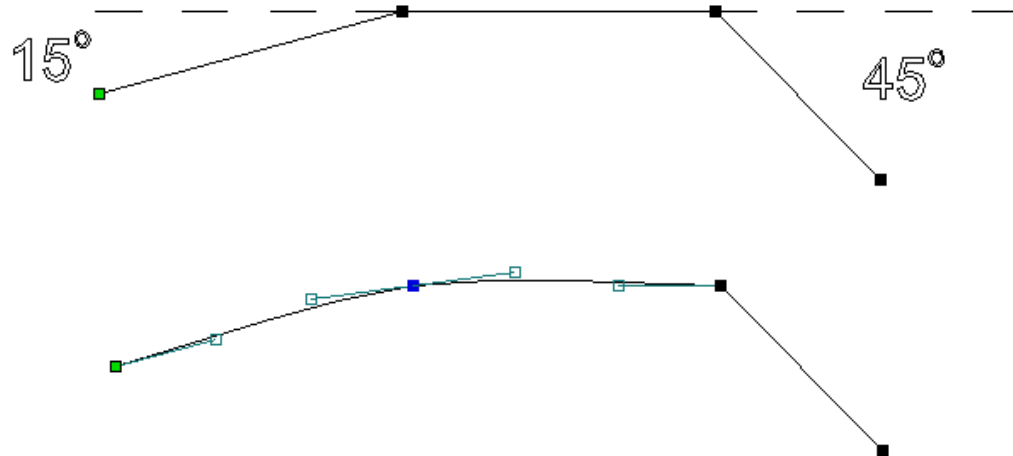

Replace selected vectors

Checking this option will delete the current vectors and replace them with the new “curve fitted” vectors. Un-checking it will keep the original vectors as is and in addition create new “curve fitted” vectors. The new vectors will always be created on the currently selected Layer.

Join and Close Vectors

The icons to join and close vectors are located under the Edit Vectors section of the Drawing Tab as shown highlighted with a red box in the image shown below: As with all the icons listed in this manual more expansive descriptions and examples can be found in the Help File under the Help drop down menu – Help Contents.

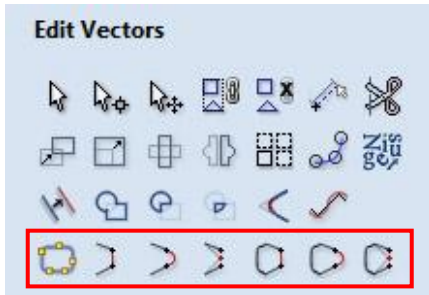

Join Vectors

Open vectors are automatically identified and closed or joined to other vectors where the end points lie within the user definable tolerance.



Join with a Line

Join with a **Line** finds the closest end points on 2 selected, open vectors and joins with a straight line.



Join with a Curve

Join with a **Curve** finds the closest end points on 2 selected, open vectors and joins them together with a smooth curve.



Join Moving End Points

Join Moving End Points finds the closest end points on 2 selected, open vectors, calculates the mid point between them and moves the end points to this position.



Close vector with Line

Close with a **Line** closes a single open vector with a straight line between its two end points.



Close Vector with Curve

Close with a **Curve** closes a single open vector with a flowing curve between its two end points.



Close Vector Moving End Points

Close Moving End Points closes a single open vector by calculating the mid point between the end points and moves them both to this position.

Align Objects

The icons to align Vectors, Bitmaps and Component Grayscale's are located under the Align Objects section of the Drawing Tab as shown below:

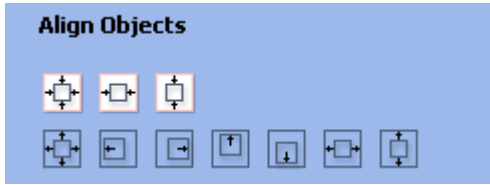

The first set of icons all work in relation to the material (job size) and the second row of icons all work with regard to the selected items – using the last selected item as the controlling object. As with all the icons listed in this manual more expansive descriptions and examples can be found in the Help File under the Help drop down menu – Help Contents.



Center in Material

This option moves the selected items to be positioned in the middle of the material. ShortCut key for this is F9.



Center in Material X only

Align vectors centrally in the material only moving them along the X axis so the vertical position will not be changed.

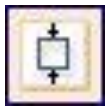

Center in Material Y only

Align vectors centrally in the material only moving them along the Y axis so the horizontal position will not be changed.

Vectors, Bitmaps and Component Grayscale's can be aligned relative to one another in the 2D View. The selection sequence to achieve this is:

1. Select the item/s you wish to align / move (use single or multiple selection options)
2. Hold the Shift key down
3. Select the final item – this is the object that the rest of the selected items will be aligned to
4. Click the required alignment option

There are 7 alignment options,

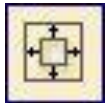

Align Center

Center selected vectors in the **Middle** of the last selected vector

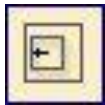

Align Left

Align the selected vectors to the **Left** edge of the last selected vector

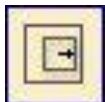

Align Right

Align the selected vectors to the **Right** edge of the last selected vector

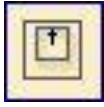

Align Top

Align the selected vectors to the **Top** edge of the last selected vector



Align Bottom

Align the selected vectors to the **Bottom** edge of the last selected vector



Align horizontal center

Align the selected vectors **Horizontally** centered to the last selected vector



Align vertical center

Align the selected vectors **Vertically** centered to the last selected vector

Layer Management

Vectors, Bitmaps and Component Grayscale's can be assigned to different layers making managing complicated designs much easier. There are no specific rules for how to use the Layers for organization. Individual users develop their own approaches as they find their preferred way of organizing their data. The main benefit of using Layers is the ability to display and un-display all the items on a particular layer. This means that as a design gets more complex it is possible to switch off items to make it simpler to work on the parts you are currently working on.

One example might be a project that requires decorative v-carving plus pocket machining, drilling and finally profile cut out passes. Each set of vectors can be assigned to different layers which would be associated with the toolpaths that were being created. Each layer can then be assigned a specific color and can either be visible or invisible as required at each stage of operation.

Being able to quickly and easily turn layers on or off makes selecting and viewing elements in a project much easier.

The Layer controls are positioned at the bottom of the Drawing Tab as shown in the image shown below:



From this set of controls the user can do the following operations to Layers: Change the currently selected layer, create layers, delete layers, rename layers, change the layers color, switch the layers visibility on and off and finally lock and un-lock individual layers. In addition to these functions there is an icon to access the Layer Control Manager.

The 'Sheet' dropdown is only used when nesting and is explained in detail in the nesting section of the manual.

Layer Control Manager

The **Layer Control Manager**  makes it very easy to work with complex designs giving quick access to all of the layer control options. This window can be left open while working and dragged around the interface and resized as required.

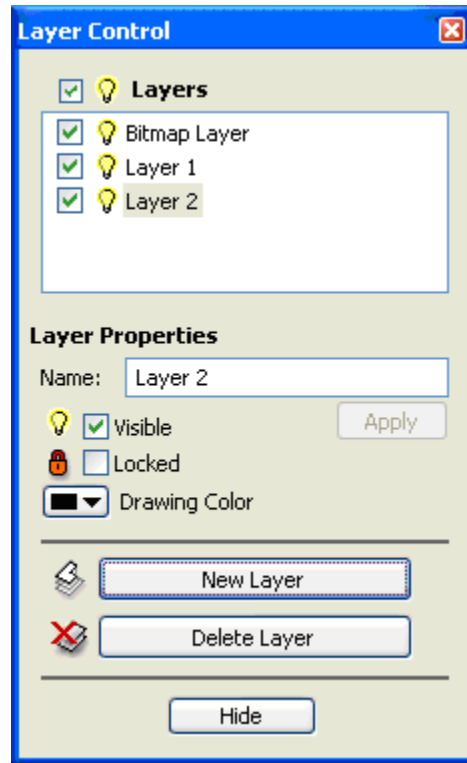

Note: Imported images are automatically placed on a layer called Bitmap Layer. This allows images to quickly and easily be turned off in the 2D view when they are not required. The images can also be moved onto another layer if required.

Name:

A Layers name can be changed by selecting the Layer, then typing the new name into the Name: area of the form and hitting Apply.

Visibility:

Visible Layers can be switched off (made invisible) by un-checking the box next to the light bulb icon. This can help to simplify what is currently displayed making it easier to work with complex designs in the 2D view.

Lock:

Layers on a vectors can be locked by checking the box next to the red pad-lock icon to stop them being selected, moved or deleted.

Colors:

The color of vectors on a specific layer can be changed to make it easier to differentiate between different regions of a design.

New Layers:

New Layers can be added using the Create New Layer button. The dialog for adding the new layer is displayed with options to specify the name and color of the vectors on the new layer and an option to indicate if the new layer should be visible.



Moving Layers:

Objects on any layer can be moved onto another layer using the Right Mouse menu or using the layer control manager. The quickest way to move objects from one layer to another is to use the Right mouse button. To do this, first select the objects you wish to move, then click the Right Mouse button and select Move to Layer and select the required option – the Right Mouse Click menu is shown in the image below:

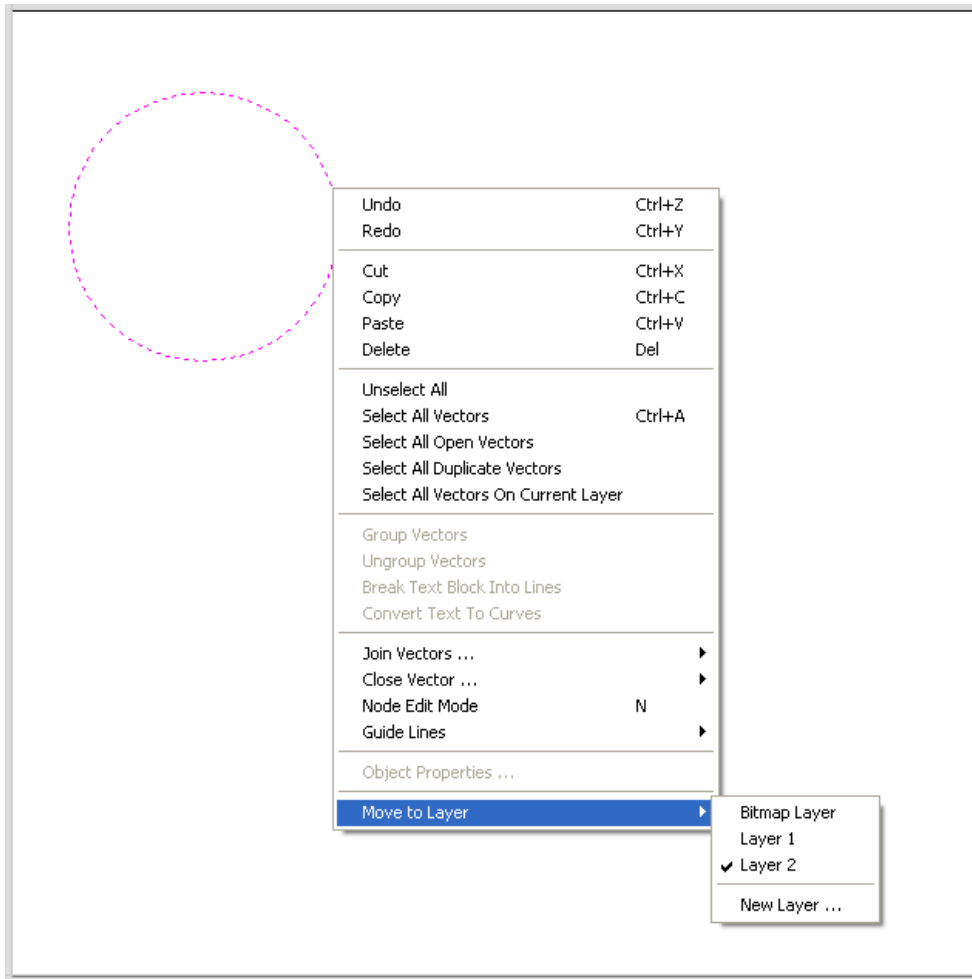

Rulers, Guidelines and the Snap Grid

To help with drawing, construction and layout, the 2D View has Rulers which are displayed along the top and down the left side of the window. In addition to the Rulers there is the option to use Guidelines to help with construction of vectors or positioning of other objects in the 2D View.

Rulers

The Rulers are permanently displayed in the 2D view to help with positioning, sizing and alignment. The graduated scale automatically uses the units set for the project and zooming in / out shows the sizes in 10ths.

Inches - 1" > 0.1" > 0.01" > 0.001" > 0.0001"

Metric - 1cm > 1mm > 0.1mm > 0.01mm > 0.001mm

Guidelines

Guide Lines are used to help layout designs and make it very easy to sketch shapes by clicking on the intersections of Guides. Guide Lines are easily added to the 2D view by Clicking with the left mouse button on the appropriate ruler (left if you want a vertical guide and top if you want a horizontal guide) then holding the button down and dragging the mouse into the 2D window.

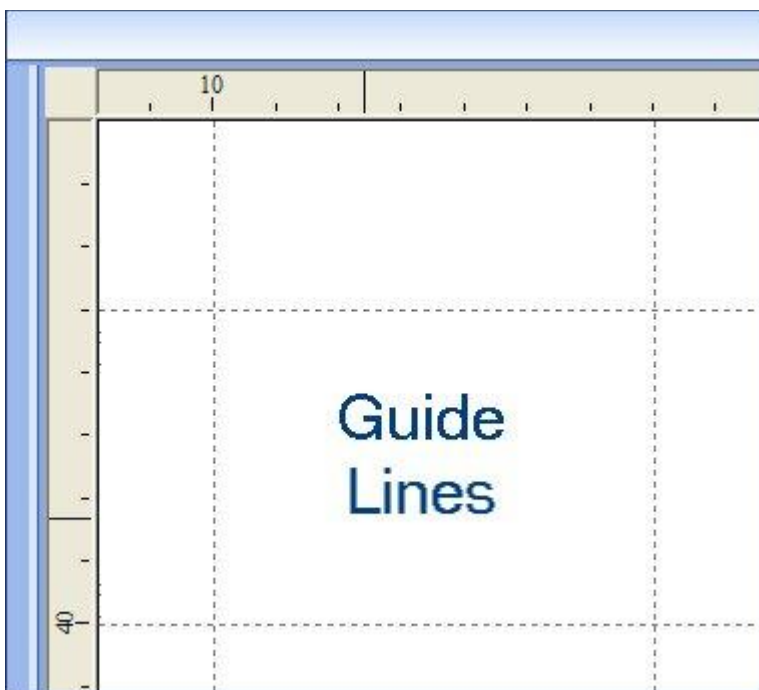

While dragging a Guide into position it automatically Snaps to the units displayed on the ruler. This snapping behaviour can be over-riden by holding down the shift key while dragging the guide. After positioning a Guide it can easily be moved to a new position by clicking the RIGHT mouse button on the guide to open the Guide Properties form as shown later in this section. If you hover the mouse over a Guideline then its current position is displayed next to the cursor

Additional guide lines can be added relative to an existing guide line by interactively placing the cursor over an existing guide (the cursor changes to 2 horizontal arrows), Holding the Ctrl key and dragging to the required position. The incremental distance between the guide lines is displayed next to the cursor. Releasing the Ctrl key changes to display the absolute distance from the material origin.

Guides can also be added and other edits made by Right clicking on the Guideline which will bring up the Guide Properties form as shown below. Using this form you can do the following things:

The exact position can be specified by entering a New Position

Guide lines can be locked in position to stop them from being inadvertently moved.

Additional Guide Lines can be added that are positioned using absolute or incremental coordinates.



Guides can quickly be toggled visible / invisible by clicking in the Top Left Corner of the 2D view as shown in the image below.

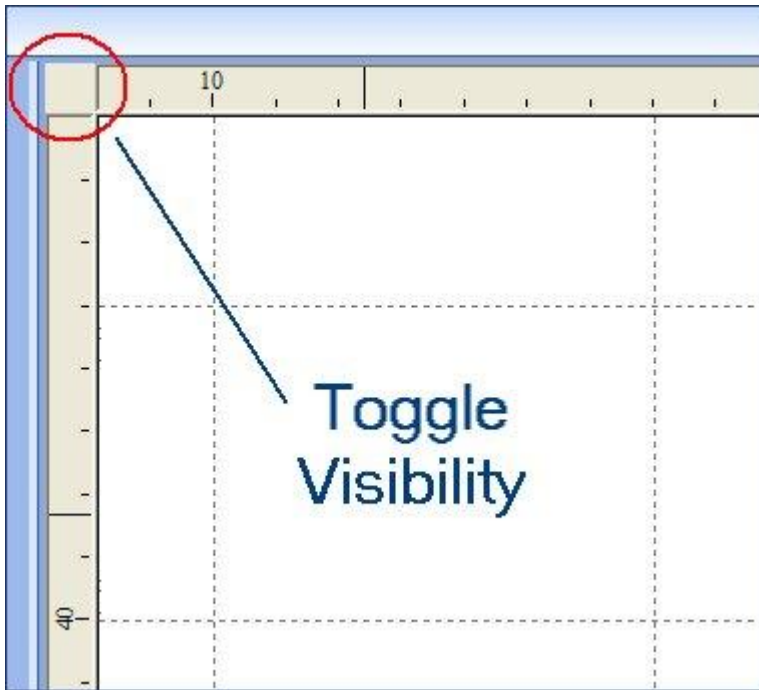

Alternatively the visibility can be changed using the drop down menu options, select: View > Guide Lines = Guides Visible / Invisible. All Guide Lines can be Deleted by selecting from the Main menu, View > Guide Lines > Delete All Guide Lines. Individual Guide Lines can be deleted by clicking and dragging them off onto the rulers.

Snap Grid

A Snap Grid with definable grid spacing can be switched on to make drawing standard shapes very quick and easy. The cursor automatically changes to show when it's snapping to a Grid points.

The Snap Grid can be switched On / Off from the Snap Settings form.

Open the Snap Settings Form by, either pressing F4 or selecting from the top Drop Down menu - Edit > Snap Options

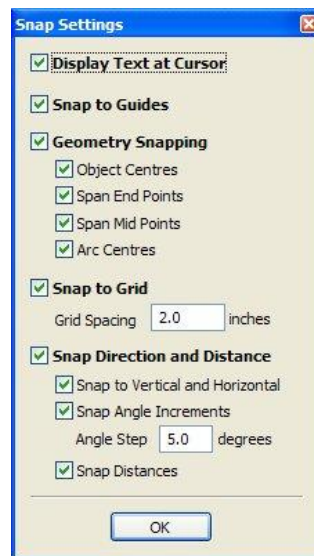

Different cursors are displayed to indicate the snapping situations and the following options can be switched on / off.

Display Text at Cursor

Displays the XY coordinates on the cursor making it easy to see the position for each point

Snap to Guides

When this option is checked drawing and positioning vectors will snap onto any horizontal or vertical guide lines visible in the 2D view.

Geometry Snapping

Used to control the position at which the cursor will snap when drawing and moving objects. When drawing the cursor will snap to items on vector geometry depending what options you have selected in the form under this section.

End points, Mid-points, Arc centers and centers of objects

Horizontally, Vertically and the specified Angle and Distance

Guide lines and the intersection of Guides

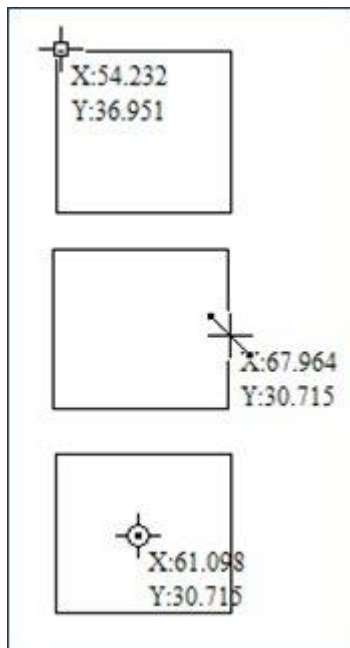

Snap to Nodes, mid-points, centers

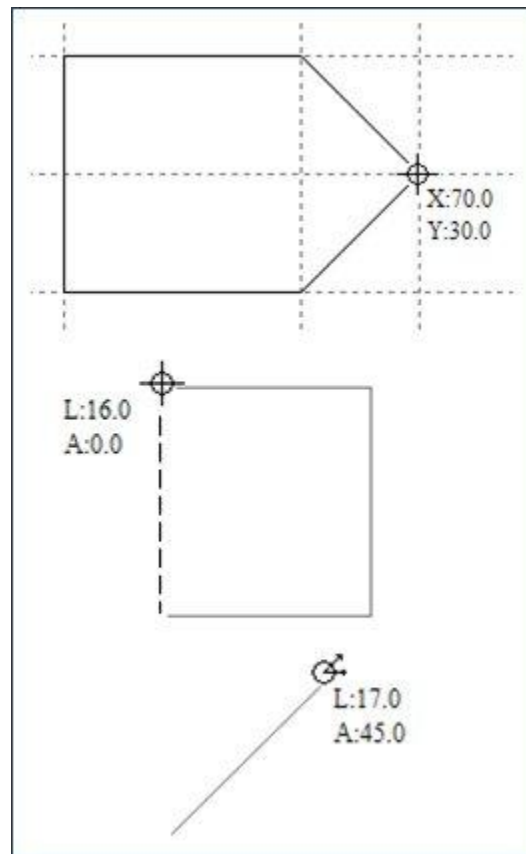

Snap to Guides, matching horizontal / vertical points, plus angle and distance

Snap to Grid

When checked this displays a grid of points set to the distance specified in the Grid Spacing. While active this points can be snapped to when drawing or editing vectors and other objects in the 2D View.

Snap Direction and Distance

When drawing lines the direction and distance can be displayed on the cursor to help construct shapes easily and quickly. The check box options below this area in the form (Snap to Vertical and Horizontal, Snap Angle Increments and Snap Distances) can be chosen to decide which of functions related to this tool you want to keep activated.

Note - Snapping can be overridden / temporarily disabled by holding the Shift key.

Toolpaths

Overview

The entire purpose (in almost all applications) of VCarve Pro is to allow the user to generate toolpaths which can be run on a CNC machine to machine the finished part in the material of choice. This requires at a minimum some vectors to describe the area a toolpath will be limited to. The general process for creating toolpath is as follows:

Prepare vectors for machining

Organize your vectors you will be using for machining onto appropriate layers

Set up your Material

Check your overall material size (Job Setup) to ensure it matches or at least fits into the piece you plan to actually cut.

Use the Material setup form from the Toolpaths Tab to set the reference Z datum for the part and the X,Y,Z machine Home position.

Create your Toolpaths

Work through the toolpath strategy icons you wish to use to carve the job to calculate all the required toolpaths.

Preview the Toolpaths

Either after you create each toolpath or at the end of calculating them all the user has the option to preview the toolpaths to see what they will actually look like in the 3D. This is a very important step to verify position, detail and the overall finished part.

*** If at any stage the Preview does not look correct then you should immediately go back to the toolpath which is wrong and make changes to try and address the problem. ***

Save Toolpaths for your CNC machine

Choosing the appropriate Postprocessor from the list the toolpaths can be saved in a format which is ready for your CNC to cut. Depending on the toolpaths calculated and the options the Postprocessor/CNC you are using has you may be able to save a single file or it may need multiple files to be saved – one for each tool type.

All the stages will be covered in the supplied Tutorial videos that cover Machining. It should be noted Stages 1 and 2 are done through icons already covered from the Drawing Tab. Stages 3 to 6 use icons from the Toolpath Tab (on the right hand side of the screen). These will be covered in the next section.

The Tool Database

The Tool Database is used to make cutter management and selection very quick and easy, and reduces the possibility of programming jobs with incorrect cut depths and speeds and feeds. This is accessed every time you create a new toolpath and allows pre-defined tools and settings (speeds, feeds, stepover etc.) to be selected from a list.

New tools can be added, copied from existing tools, deleted and ordered. All of the cutting parameters are stored in the database.

To open and manage the Tool Database you can go to the Edit drop down menu at the top of the interface and click:

Edit > Tool Database

A window similar to that shown below will appear displaying a list of the tools that are currently defined on the left and the parameters for the currently selected tool from the list over on the right. Below this image is a list of all the actions that can be executed from this dialog:

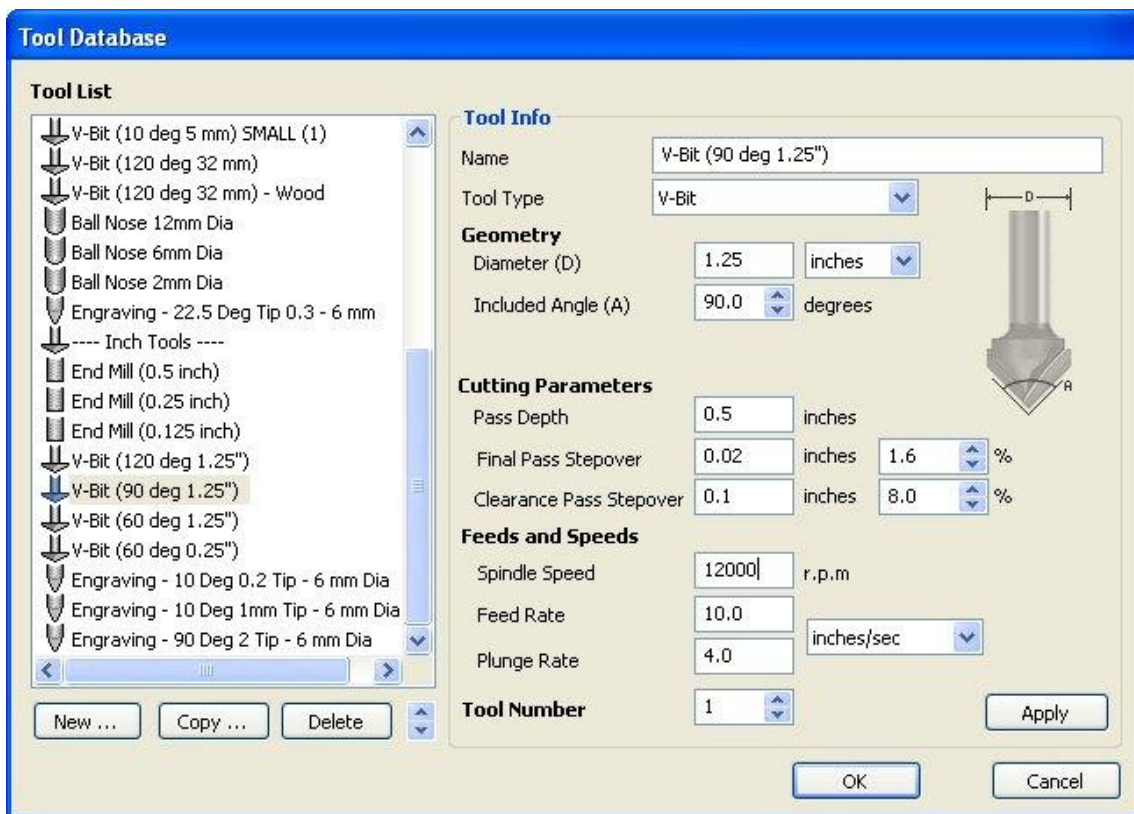

New

Selecting New creates an empty tool in the list that can have any user definable name.

Copy

Copy adds a duplicate of the selected tool to the list and prefixes the original name with (1). Edit the Name and properties for the new tool and click the Apply button to save the changes to the list.

Delete

Deletes the selected tool from the database. Take care when deleting tools as this operation cannot be undone.

List Ordering

The Up & Down arrows allow the list of tools to be ordered to the users preference.

Apply

If the properties or cutting parameters for a tool are changed, click the Apply button to save the changes and update the database.

Name

Use this field to enter a suitable name to describe your cutters.

Tool Type

9 types of cutters can be specified in the database.



V-Bit



Engraving



Radiused Engraving



Ball Nose



End Mill



Radiused End Mill



Form Cutters



Diamond Drag



Drills

Important!: When specifying the geometry for a tool, the angle specified is different for V-Bit and Engraving Tools.

V-Bit Tools are defined using an Included Angle (A), Engraving Tools are defined using the Half Angle (A) and the Flat Diameter (F)

Form Cutter - Ogee and Roundovers etc need to be drawn to the correct scale. Creating a Form cutter is discussed in the section on **Using Form Cutters** immediately following this section on the Tool Database.

Cutting Parameters

Pass Depth

The maximum depth of cut the tool can cut. The Pass Depth controls the number of z level passes that are calculated for a toolpath. For example, creating a pocket 1" (24 mm) deep using a tool that has a Pass Depth of 0.25" (6 mm) will result in the toolpath making 4 passes.

Stepover

The distance the cutter moves over when doing area clearance cutting. For example, when raster machining the cutter will machine along the X axis, stepover in the Y direction and return parallel to the first line of cut. The greater the stepover the faster the job will be machined, but this must be balanced with the material being cut and the tooling being used, to ensure that the tool does not break.

When stepovers greater than 50% of the cutter / tip diameter are used the software automatically adds "Tail" moves in the corner regions of toolpaths to ensure material is not left on the job.

When using **V-Bit Tools** the Stepover fields automatically change to use the following options.

Final Pass Stepover

The distance the cutter moves over when finish machining and is usually set to be a relatively small distance to produce a smooth surface finish on the job.

Clearance Pass Stepper

Only used when a V-Bit tool is being used to rough machine at multiple Z levels down to a specified flat depth. This stepper can be much larger than the Final Pass Stepper because the tool is only rough machining material away. Increasing the Clearance Pass Stepper will reduce the machining time, but you must be careful to ensure it is not too great for the material being cut.

Feeds and Speeds

Spindle Speed

Speed of tool rotation, specified in revolutions per minute

Feedrate

The surface cutting rate at which the cutter is moved into the material. The units can be specified in distance per second or minute.

Plunge Rate

The cutting rate at which the cutter is moved vertically into the material. The units can be specified in distance per second or minute.

Note: The Feedrate and Plunge rate you should use will vary depending upon the material being machined and the tooling being used.

Tool Number

This is the number of the tool needed to machine the job. When using a CNC machine with an Automatic Tool Changer (ATC), it is critical that the correct tool required to cut the job is located in the corresponding carousel location.

Using Form Cutters

Form Cutters can be added in the Tool Database so industry standard Ogee and Round-over type cutters, plus user definable custom shapes can be used for edge profiling and decorative carving. Examples of these types of cutters and the kind of cuts they can be used for are shown in the images below:



Roundover

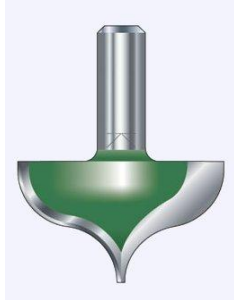

Ogee



Profile Cutting Strategy with Form cutter

Adding a Form cutter to the Tool Database is straightforward and the procedure is,

1. Draw to scale the Right side of the cutter geometry in the 2D Window
2. Use the Node Editing tools to create the arcs and curves etc.

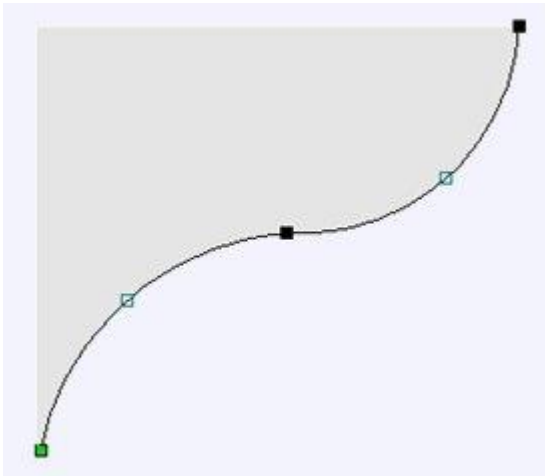

Only draw the Right-hand side of the cutter geometry to the correct size and scale as shown in the image above.

The shape can be a combination of Lines, Arcs and Bezier spans

3. With the vector Selected open the Tool Database by clicking,

Edit > Tool Database

4. Click New Cutter > Form Tool

The selected geometry will be imported and a profile displayed in the window.

5. Give the Cutter a meaningful name and complete the cutting parameters – speeds and feeds etc.
6. Click the Apply button to save the new cutter into the database list so it can be used at any time.

Note Cutter geometry can be imported as dxf or eps files and used to create Form Tools in the database.

The Toolpath List

The Toolpath List is located at the top of the Toolpath Tab (toggle tab visibility using Short Cut key F12). Below you can see an image of this:

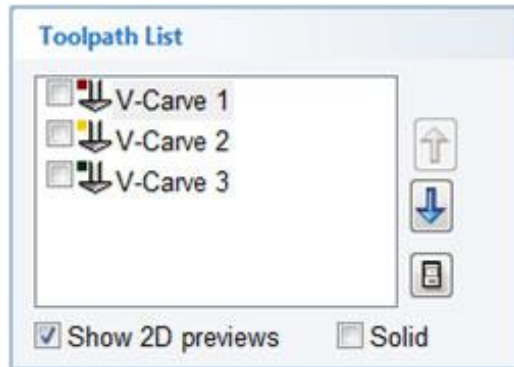



Toolpath List

Displays in a list the name of each calculated toolpath with a check-box to turn the visibility of the toolpath in the 3D View on and off. The icon next to the check-box shows the type of tool selected for that particular toolpath.

Double clicking the name of any of the toolpaths will open up the toolpath strategy window for that toolpath and allow edits to be made to it.

Up down arrows

The up and down arrow icons to the right of the window   allow the user to move a toolpath up and down in the list. This will affect the order the Toolpaths are previewed in and if multiple toolpaths are saved as a single file then this will be the order that the machine cuts them in.

Show 2D Previews

Toggles the visibility of the Toolpaths 2D Previews in the 2D View on and off

Solid

Displays the 2D Previews in a solid color so the area cut by the toolpath can be easily seen

Floating Toolpath List

Clicking the **Toggle Display of Toolpath Manager Dialog** icon  in the bottom Right corner of the Toolpath List opens the floating Toolpath Control window (as shown below). This provides a resizable Toolpath List window that can be dragged around the interface to a more convenient position if required.

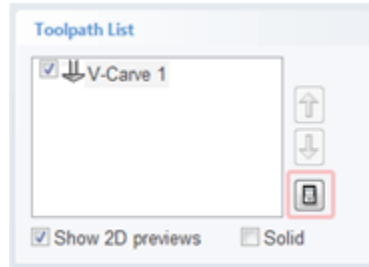

The names of the Toolpaths can be changed in this dialog without having to re-calculate the toolpath.

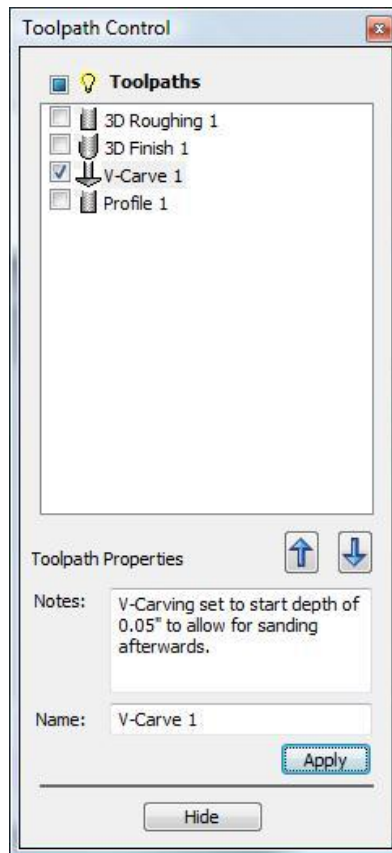

Notes:

Notes can be attached to an individual toolpath and output into the toolpath file using the [TOOLPATH_NOTES] variable in the post-processor configuration file.

```

notes.txt - Notepad
File Edit Format View Help
( House_Sign )
( File created: Monday, November 30, 2009 - 02:25 PM )
( for Mach2/3 from Vectric )
( Material Size )
( X= 18.000, Y= 12.000, Z= 0.750 )
( )
(Tools Used: 1 = V-Bit {90 deg 0.5"})
N70G00G20G17G90G40G49G80
N80G70G91.1
N90T1M06
N100 (Tool: V-Bit {90 deg 0.5"})
N110G00G43Z0.5000H1
N120S16000M03
N130(Toolpath:- V-Carve 1)
N140(V-Carving set to start depth of)
N150(0.05" to allow for sanding )
N160(afterwards.)
N170G94
N180X0.0000Y0.0000F100.0
N190G00X4.1725Y3.3298Z0.2500
N200G1X4.1725Y3.3298Z-0.1806F30.0
N210G1X4.1126Y3.3075Z-0.1583F100.0
N220G1X4.0000Y3.3601Z-0.0457
N230G1X4.1126Y3.3075Z-0.1583
N240G1X4.0000Y3.1949Z-0.0457
N250G1X4.1132Y3.3077Z-0.1585
N260G1X4.1725Y3.3298Z-0.1806
N270G1X4.1889Y3.3200Z-0.1708
N280G1X4.2083Y3.3102Z-0.1610
N290G1X4.2337Y3.3004Z-0.1512
N300G1X4.2516Y3.2955Z-0.1463
N310G1X4.2643Y3.2931Z-0.1438

```

Toolpath Operations

The Toolpath Operations icons are immediately below the Toolpath List on the Toolpath Tab. These icons are shown in the image below and a description of each icon and function associated with it is below that.



Material Setup



Setup
Material

This option opens the **Material Setup** form that is used to specify the Material Thickness, Z Zero origin, Model Position, Rapid clearance gap and Home position.

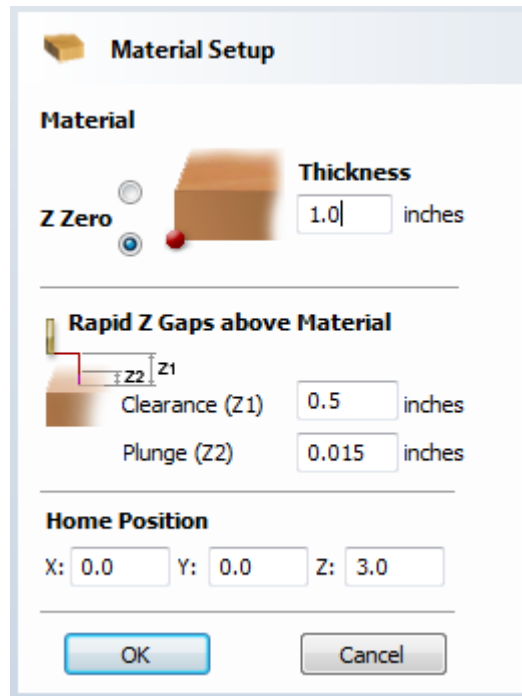

Z Zero

Select relative to the Material Surface or relative to the Machine Table / Bed. This is a very important setting because the Tooling used on the CNC machine must be setup in the same way, ensuring the toolpaths cut to the correct depth.

Thickness

Enter the thickness of the material being machined

Rapid Z Gaps above Material

Clearance (Z1)

This is the height above the job at which it is safe for the cutter to move at rapid or maximum federate. The software will raise the bottom of the cutter to this height when it traverses the material.

Plunge (Z2)

For all toolpaths, as well as specifying a rapid clearance gap for rapid positioning moves above the workpiece, the user can also specify a much smaller gap that the tool will rapid down to during plunge moves.

By default the plunge gap is set to the same value as the Clearance gap which means that there will be no rapid plunges. If you set the plunge gap to a smaller value than the Clearance gap, the tool will plunge at rapid federate to the specified distance above the material surface before changing to the specified plunge rate. For jobs where a large value for Clearance gap has to be specified to avoid clamps etc, this feature can save a considerable amount of machining time if there are a lot of plunge moves in the job. Setting a value of 0.0 for the plunge gap will also disable this feature.

Note: Some engraving machines are not able to take advantage of this feature.

Home Position

This is the absolute position that the tool will start moving from and where the tool can be programmed to return to at the end of cutting the job.

VCarve Toolpath



VCarve Toolpath

This icon opens the **V-Carving Toolpath** form which is used to specify the type of carving required, tooling details, cutting parameters and name for the toolpath.

Clicking this icon will activate the form shown below:

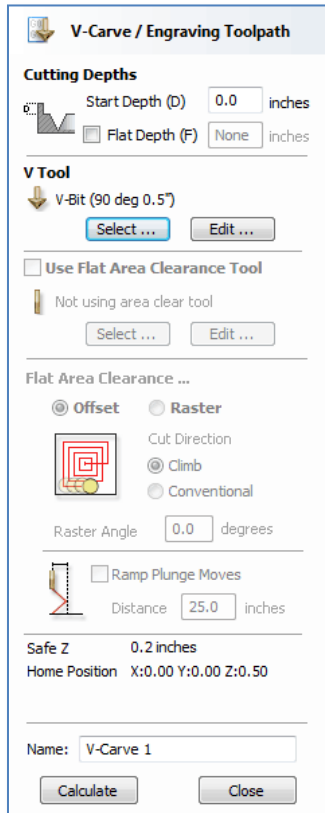

The screenshot shows the 'V-Carve / Engraving Toolpath' dialog box. It contains several sections: 'Cutting Depths' with 'Start Depth (D)' set to 0.0 inches and 'Flat Depth (F)' set to None; 'V Tool' with a 'V-Bit (90 deg 0.5")' selected; 'Use Flat Area Clearance Tool' which is unchecked; 'Flat Area Clearance ...' with 'Offset' selected and 'Raster' unselected; 'Ramp Plunge Moves' which is unchecked; 'Safe Z' set to 0.2 inches; 'Home Position' X:0.00 Y:0.00 Z:0.50; and a 'Name' field containing 'V-Carve 1'. 'Calculate' and 'Close' buttons are at the bottom.

Cutting Depths

Start Depth (D) specifies the depth at which the vcarving toolpath is calculated, allowing VCarving / Engraving to be machined inside a pocket region. When cutting directly into the surface of a job the Start Depth will usually be 0.0. If the vcarving / engraving needs to be machined into the bottom of a pocket or stepped region, the depth of the pocket / step must be entered. For example, to carve or engrave into the bottom of a 0.5" deep pocket, the Start Depth = 0.5"

Flat Depth (F)

Checking this option limits the depth that the tool(s) will machine to, and is used for Flat Bottomed Carving and Engraving.

When No Flat Depth specified the toolpath will be calculated to carve or engrave to full depth as shown below. Multiple z level passes will be automatically calculated where the tool needs to cut deeper than its Pass Depth specified in the Tool Database.

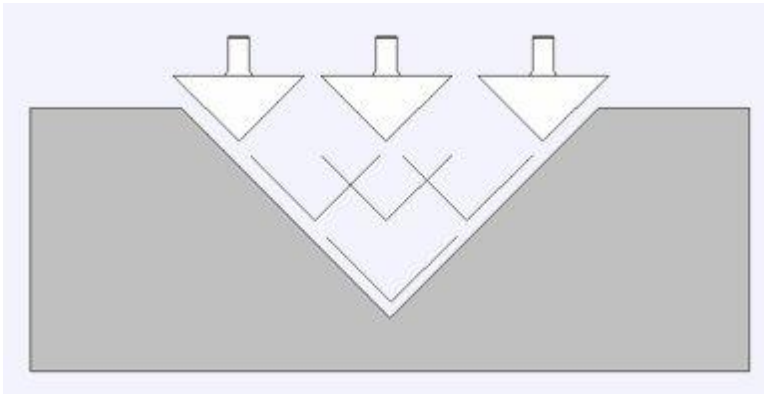

No Flat Depth

Single tool machines the complete job.

Multiple z level passes calculated using the Pass Depth specified for the selected tool.

Clicking the option for Flat Depth and entering the required depth will result in flat pocket areas being machined where the width between vectors would result in the tool cutting deeper than the specified Flat Depth.

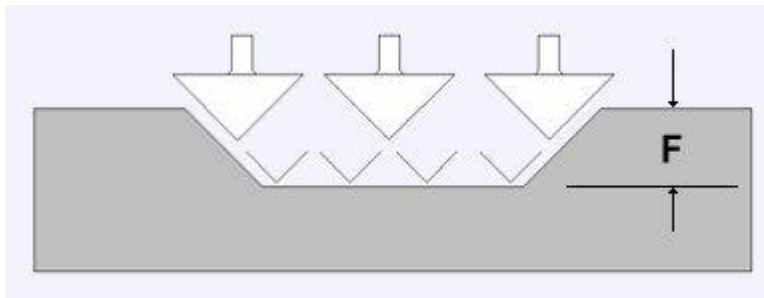

Flat Depth

Complete toolpath is calculated using a single V-Bit or Engraving tool.

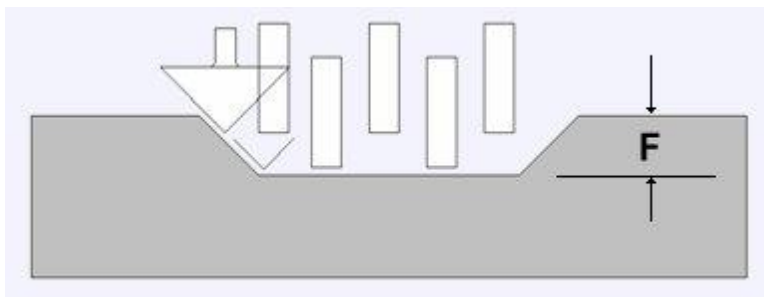

Flat Depth

Using 2 tools.

End Mill to create the flat pocket regions followed by V-Bit or Engraving tool to cut the detail and corner regions

V Tool

Clicking the Select button opens the Tool Database from which the required VCarving or Engraving Tool can be selected. See the section on the Tool Database for more information on this.

Clicking the Edit button opens the Edit Tool form which allows the cutting parameters for the selected tool to be modified, without changing the master information in the database. Note that Ball nosed tools can also be used to vcarve designs.

Use Flat Area Clearance Tool

Check this option if you wish to use an End Mill, Ball Nose or Engraving cutter to machine the large open regions of a design. Note that this option is only available when Flat Depth is selected. If not tool is selected here but Flat Depth is specified then the specified VCarving tool will be used to clear the flat areas as well as for the VCarving.

Clicking the Select button opens the Tool Database from which the required End Mill or Engraving Tool can be selected.

Clicking the Edit button opens the Edit Tool form which allows the cutting parameters for the selected tool to be modified, without changing the master information in the database.

Flat Area Clearance

This section of the form allows you to choose the strategy which will be used to clear the flat bottomed area with the Flat Area clearance tool. These options are the same as those found on the pocketing form.

Ramp Plunge Moves

If this option is selected ramps are added to the plunge moves for the pocketing toolpath.

Safe Z

The height above the job at which it is safe to move the cutter at rapid / max feedrate. This dimension can be changed by opening the Material Setup form.

Home Position

Position from and to that the tool will travel before and after machining. This dimension can be changed by opening the Material Setup form.

Name

The name of the toolpath can be entered or the default name can be used. Note that two toolpaths will be calculated if an Area Clearance Tool is used and the toolpath for the End Mill will have the word Pocket appended to the specified name.

Profile Toolpath

Profile Machining options provide the flexibility for cutting shapes out with optional Tabs / bridges plus an Allowance over/undercut to ensure perfect edge quality.

The 3D Bevel machining strategy chamfers the edge of shapes and includes 3D sharpening moves into corner regions.



Profile Toolpath

Profile toolpaths can be outside, inside or on the selected closed vectors, automatically compensating for the tool diameter and angle. These machining strategies can use any of the cutter types supported and the toolpaths will automatically offset to compensate for the geometry of the selected tool.

When working with open vectors the profile toolpaths can be to the Left, to the Right or On the selected vectors.

Clicking this icon opens the 2D Profile Toolpath form which is shown below; the functions in this form are described on the following pages.

2D Profile Toolpath

Cutting Depths

Start Depth (D) 0.0 inches

Cut Depth (C) 0.125 inches

Tool

End Mill (0.125 inch)

Select ... Edit ...

Machine Vectors...

Outside / Right

Inside / Left

On

Direction Climb Conventional

Allowance offset 0.0 inches

Use vector start points (don't optimize)

Tabs | Corners | Leads | Ramping |

Add tabs to toolpath

Length 0.5 inches

Thickness 0.08 inches

Create 3D tabs

Edit Tabs

Safe Z 0.2362 inches

Home Position X:0.00 Y:0.00 Z:0.79

Name: Cut Out

Calculate Close

Cutting Depths

Start Depth (D) specifies the depth at which the Profile toolpath is calculated. When cutting directly into the surface of a job the Start Depth will often be 0. If machining into the bottom of an existing pocket or stepped region, the depth of the pocket / step must be entered.

Cut Depth (C)



The depth of the profile toolpath relative to the Start Depth.

Tool

Clicking the Select button opens the Tool Database from which the required tool can be selected. See the section on the Tool Database for more information on this. Clicking the Edit button opens the Edit Tool form which allows the cutting parameters for the selected tool to be modified, without changing the master information in the database.

Machine Vectors

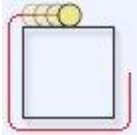
There are 3 options to choose from to determine how the tool is positioned relative to the selected vectors/s

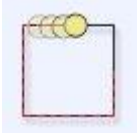
Outside		Calculates a profile toolpath around the Outside of the selected vectors, with options for the cut direction to be either,
		Climb (CW) cutting direction
		Conventional (CCW) cutting direction
Inside		Calculates a profile toolpath around the Inside of the selected vectors, with options for the cut direction to be either;
		Climb (CCW) cutting direction
		Conventional (CW) cutting direction
On		Calculates a profile toolpath around the On the selected vectors, with options for the cut direction to be either,
		Climb (CW) cutting direction
		Conventional (CCW) cutting direction

Cut Direction

Can be set to either Conventional or Climb machining where the cutting direction depends upon the strategy selected - see above for details. Using Climb or Conventional cutting will largely be dictated by the material is being machined.

Allowance

An Allowance can be specified to either Overcut (negative number will cut smaller) or Undercut (positive numbers will cut larger) the selected shape. If the Allowance = 0 then the toolpaths will machine to the exact size.

Start Point

Use Start Point can be selected to force the toolpath to plunge and start cutting at the first point on the shape. This is very useful if you need to ensure the cutter doesn't plunge onto a critical part of the job. For example, setting the Start Point to be on a corner will often be the best position to plunge and cut from as this will not leave a witness / dwell mark on the machined surface.

The Start Points are displayed as Green boxes on all vectors when this option is selected. Start Point on a vector can be moved using the Node Editing Tools. Select Node Editing cursor or press N. Place the cursor over the node to be used as the Start Point. Click Right mouse button and select Make Start Point (or press P) Remember, you can also insert a new point anywhere on a vector using the Right mouse menu or pressing the letter I. This point can then be set to be the New Start Point

Note

Selecting Use Start Point may result in less efficient toolpaths (increased cutting times) because it may take the machine longer to move between each shape being cut. If this option is not selected the software will try to calculate the shortest toolpath, minimizing the distance between link up moves. But the downside is that the cutter may plunge/mark important surfaces on the machined edge.

Profile Options

There are four dialog pages (Tabs, Corners, Leads, Ramping) which allow Profile machining options to be specified. These help control ways to ensure the parts are held in place and machined as easily as possible while ensuring the highest quality edge finish.

Tabs (Bridges)

Tabs are added to open and closed vector shapes to hold parts in place when cutting them out of material. Checking the Add tabs option will activate this option. The Length and Thickness specify the size of each tab. Checking the Create 3D Tabs option will create 3D Tabs, the difference between this and 2D Tabs is described below.

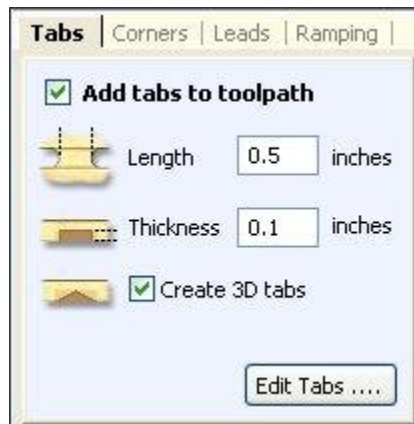

3D Tabs

When this option is selected the tab will be triangular in section. This shape is created as the cutter ramps up to the specified Tab Thickness then down the other side. The 3D Tabs will often allow the machine to run quicker and smoother because it does not have to stop to move in Z at the start and end of each tab

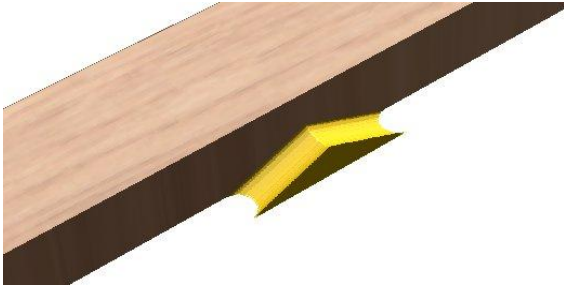

2D Tabs

The cutter stops at the start point for each tab, lifts vertically by the specified Thickness runs across the ramp, stops and plunges down the other side.

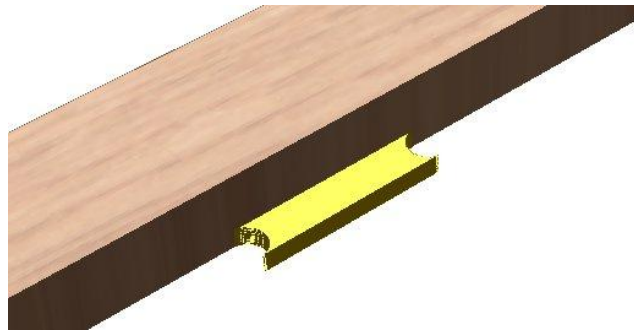

The image below shows how the length and thickness values apply to each type of tab.

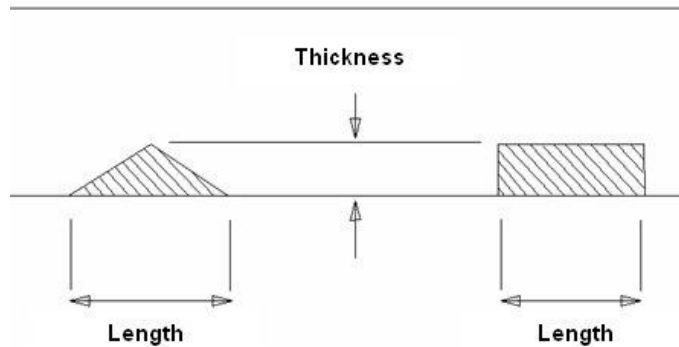

Edit Tabs

Clicking on the Edit Tabs button automatically opens the 2D window and the following form is displayed.

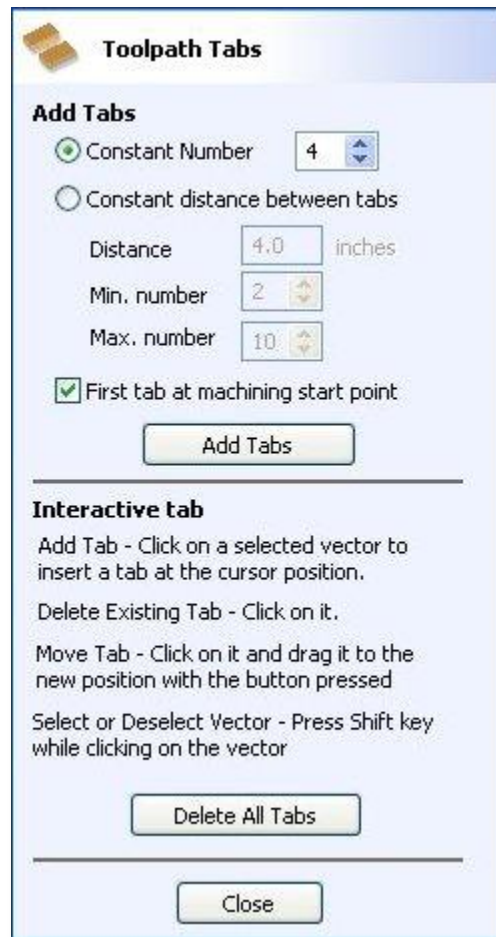

Add Tabs

Constant Number

calculates the length of each selected vector and places 'X' number of equally spaced Tabs around the shape

Constant Distance between tabs

This option places a tab at the specified distance around the selected shape.

If placing Tabs at the Distance around the shape results in fewer than the Min number, the minimum number of Tabs are automatically equally placed on the shape.

If the number of tabs calculated using the Distance around the shape is greater than the specified Max number, the Max number are placed at equal distance around the shape.

First tab at machining start point

If checked, a Tab will be placed at the start point (Green node) of a vector when the option First Tab at Machining Start Point is selected.

Notes on dynamically positioning tabs in the 2D View

Interactive Tab positioning is very easy. Simply place the cursor at the point where the Tab is required and click the Left mouse. To Move a Tab, Click and Drag with the Left mouse button on a Tab to move.

To Delete a Tab, place the cursor over an existing tab and click the left mouse button.

NB: The best place to put Tabs on a part is on the flat areas so they can easily be removed and tidied up.

The quickest method for adding Tabs to multiple shapes is to use the automatic option to add 'X' number. The position of these can then very easily be modified by clicking and dragging to move tabs to the 'best positions' and also delete unwanted tabs.

That covers all the options for defining tabs the second choice on the Profile Options is to control the toolpath in the Corners of the vectors:

Corners

Choosing this tab and checking the option **Sharp external corners** (see below) forces the cutter being used to cut the shape out, to machine around the shapes and retain any square corners.



Sharp External Corners

This option makes adding beveled edges to a 2D shape very quick and easy, this can be a good way to turn simple 2D cut out lettering into a high quality signage products that look more interesting or provide a different option for customers.

This is an example of the type of effect that can be created by using this option:



Standard Profile toolpaths without the Sharp Corners switched on roll around the sharp corners. This still gives a point on a straight sided tool but will give a radiused edge when using a V-bit.

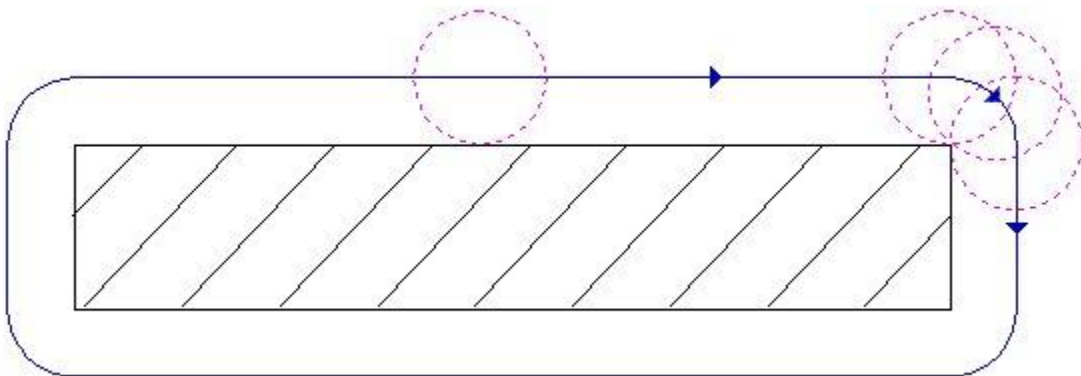

When **Sharp External Corners** is selected the following change is made to the toolpath (see image below) so it makes sharp external corners as shown in the image of the letter 'M' at the top of the page.

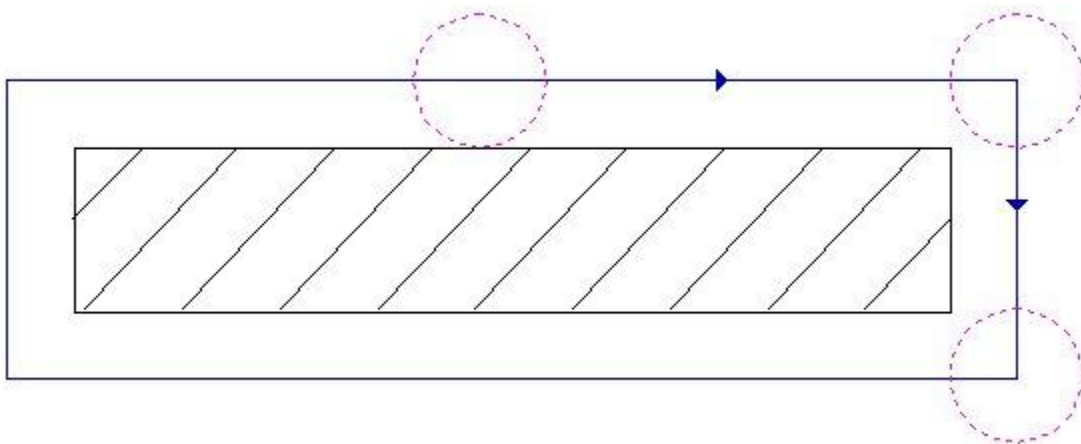

Sharp Internal Corners

When Sharp Internal Corners is selected the tool will raise up into internal corners to sharpen them with its point. The difference between checking this and leaving it unchecked is shown in the two images below.

First image shows standard internal corners with the option un-checked.

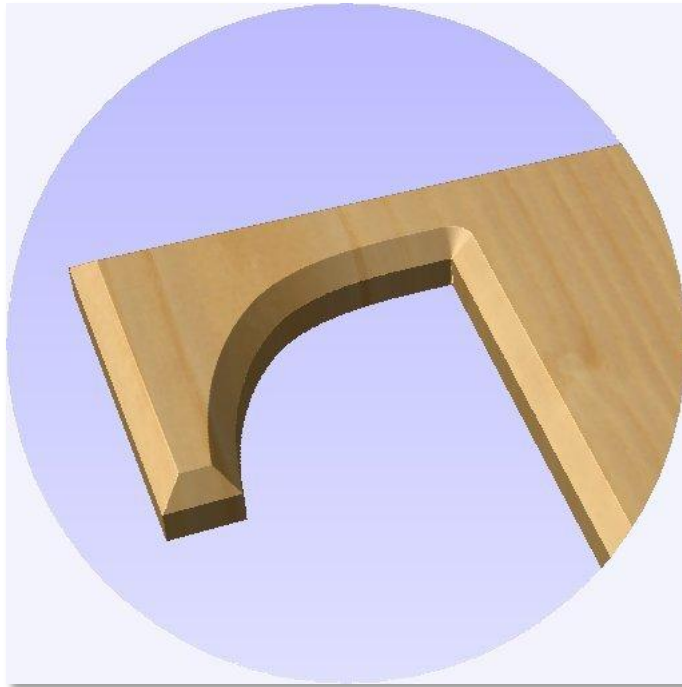

This second image shows the toolpath calculated with Sharp Internal Corners checked.

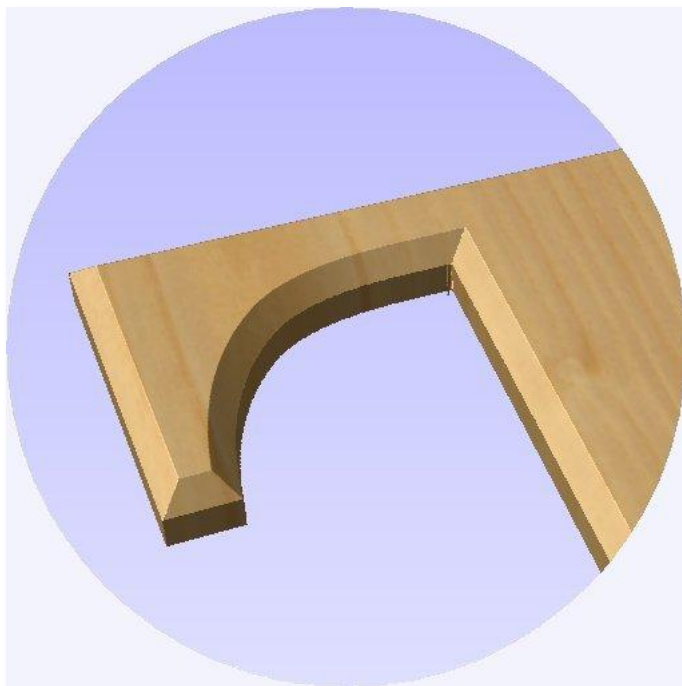

Allowance for Cut out tool

Sharp internal corners are often used when creating beveled letters. In this case, the letters usually have straight 'returns' which are machined with a straight sided end mill. The cut out pass for the end mill needs to be offset from the vector to allow for the bevel created by the tool. This field displays the value you will need to enter into the 'Allowance Offset' field when you create your cut out profile toolpath for the end mill. You can select the value with the mouse and used Ctrl+C to copy it to the clipboard and then copy it into the 'Allowance Offset' field when you create the cut out toolpath.

That has covered all the options for controlling the Corners, the third choice on the Profile Options is to control the Leads for the Toolpath.

Leads

Lead In and Lead Out

Lead in / out moves can be added to profile toolpaths to help preventing marking the edges of components with dwell marks that are typically created when a cutter is plunged vertically on the edge of the job.

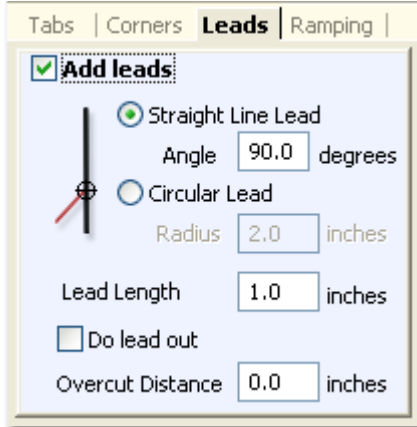

Straight Line Lead

This option creates a linear lead onto the cutterpath using the **Angle** and **Lead length** distance specified.



The toolpath will lead onto the selected edge at the specified **Angle**.

Checking the **Do lead out** option results in an exit lead being added at the end of the toolpath off the machined edge.

The **Overcut Distance** forces the cutter to machine past the start point and is often used to help produce a better edge quality on parts.

Circular Lead

This option creates an arc lead onto the toolpath using the **Radius** and **Lead length** distance specified.



The toolpath will curve onto the selected edge, tangent to the direction of the vector at the point it reaches the actual geometry edge.

Checking the **Do lead out** option results in an exit lead being added at the end of the toolpath off the machined edge.

The **Overcut Distance** forces the cutter to machine past the start point and is often used to help produce a better edge quality on parts.

That covers all the options for controlling the Leads, the last choice on the Profile Options area is to control the Ramps for the Profile Toolpath.

Ramping

Ramp moves are used to prevent the cutter from plunging vertically into the material. The cutter gradually cuts at an angle dropping into the material and this significantly reduces cutter wear, heat build-up and also load on the router spindle and Z axis of the machine. If multiple passes are required due to the Pass Depth being less than the Cut Depth, the ramp moves are applied at the start of each level.

Smooth

This option creates a smooth ramp into the material using either the specified Distance or Angle.

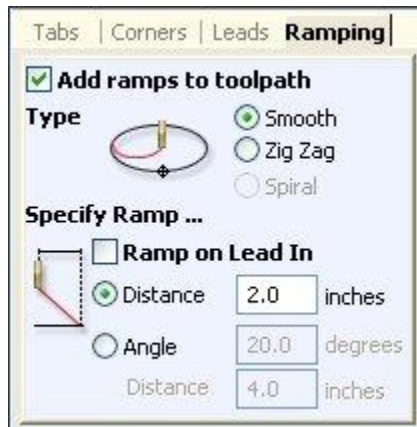

When a Lead In distance has been specified, the option **Ramp on Lead In** disables the distance and angle options and automatically limits the ramp moves to only be on the lead in portion of the toolpath.

Zig Zag

This option ramps into the material by Zig-Zag backwards and forwards using either the specified Distance or Angle.& Distance.

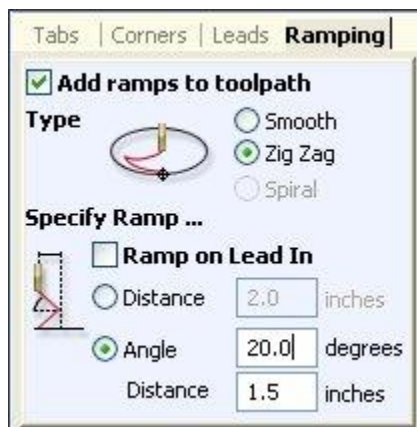

The Distance option ramps into the material, zigging for the specified distance in one direction then zagging back over the same distance.

The Angle and Distance option is typically used for cutters that cannot plunge vertically but have an entry angle specified by the manufacturer

Spiral

Checking this creates a continual spiral ramp, these are only available when the toolpath does not include lead in moves.

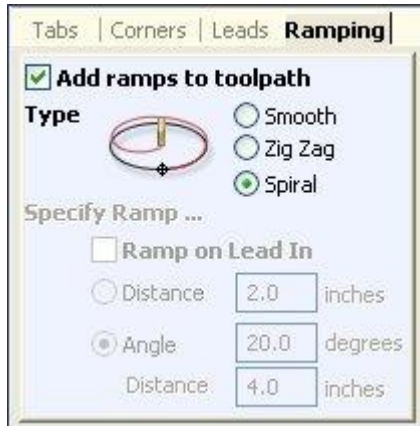

This option ramps into the material over the complete circumference of the profile pass. The angle is automatically calculated to ramp from the start point to full depth over the perimeter distance around the job.

The rate at which the cutter ramps into the material is determined by the **Pass Depth** specified for the cutter. For example, Spiral Profiling 0.5" deep with a cutter that has a Pass depth of 0.5 or greater will spiral down in 1 pass. Editing the Pass depth to be 0.25" results in the 2 spiral passes around the profile.

Safe Z

The height above the job at which it is safe to move the cutter at rapid / max feedrate. This dimension can be changed by opening the Material Setup form.

Home Position

Position from and to that the tool will travel before and after machining. This dimension can be changed by opening the Material Setup form.

Name

The name of the Profile toolpath can be entered or the default name can be used.

Additional notes on Profile Machining –

Machining Open Vectors

The direction of open vector(s) is very important when using Profile strategies as this is used to determine which side of the selection is the right and left for machining. Selecting Node Edit mode (pressing N on the keyboard) will display a Green node at the start of the vector. Looking along the vector(s) from the green node indicates the direction and the image below shows offsets to the left and right of an open vector.

The Cut Direction - Conventional or Climb controls which end of the open vector the toolpath will start. Changing the cut direction will reverse the direction of cut.

Conventional starts cutting at the Start point

Climb cutting starts cutting at the end point

A graphic is shown below to demonstrate this.

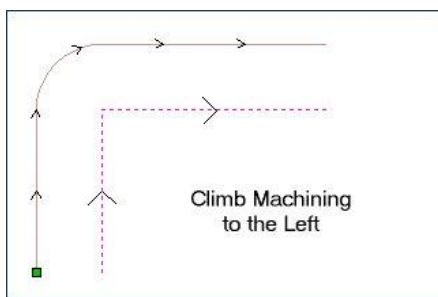

Profile machining to the Left of the vector using Climb cutting (vector is pink dotted line – other line with arrows shows the toolpath).

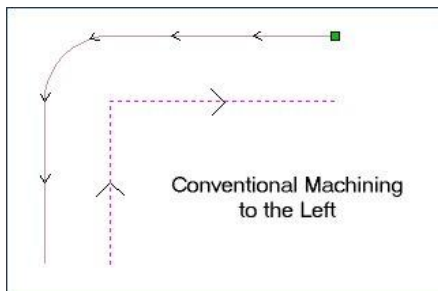

Profile machining to the Left of the vector using Conventional cutting (vector is pink dotted line – other line with arrows shows the toolpath).

Talk to your material and tooling suppliers for details about what is most appropriate for your specific type of work.

Tabs can be added to open profile toolpaths

Sharp External Corner options do not apply because identifying the outside / inside of an open shape is ambiguous.

Leads cannot be added to open profile toolpaths.

Ramps can be added to open profile toolpaths.

Pocketing Toolpath



2D Pocket Toolpaths

This option opens the Pocket Toolpath form for machining 2D pockets. These toolpaths automatically compensate for the tool geometry - diameter and angle.

Clicking on this icon opens the following toolpath form, the functions available within this are described after the image.

Pocket Toolpath

Cutting Depths

Start Depth (D) 0.0 inches

Cut Depth (C) 0.5 inches

Tool

End Mill (0.25 inch)

Select ... Edit ...

Use Larger Area Clearance Tool

Not using area clear tool

Select ... Edit ...

Clear Pocket ...

Offset **Raster**

Cut Direction

Climb **Conventional**

Raster Angle 0.0 degrees

Profile Pass Last

Pocket Allowance 0.0 inches

Ramp Plunge Moves

Distance 1.0 inches

Safe Z 0.2 inches

Home Position X:0.00 Y:0.00 Z:0.50

Name: Pocket 1

Calculate Close

Cutting Depths

Start Depth (D) specifies the depth at which the toolpath is calculated. When cutting directly into the surface of a job the Start Depth will often be 0.

Cut Depth (C)

The depth of the toolpath relative to the Start Depth.

Tool

Clicking the Select button opens the Tool Database from which the required tool can be selected. See the section on the Tool Database for more information on this. Clicking the Edit button opens the Edit Tool form which allows the cutting parameters for the selected tool to be modified, without changing the master information in the database.

Use Larger Area Clearance Tool

If this option is selected two tools are used to clear the pocket. A large tool to do the bulk of the area clearance and a smaller tool (the first tool selected) to remove the remaining material and do a final profile pass.

Clear Pocket

There are two choices of the type of “fill pattern” that will be used to clear away the area to be machined with the Pocket Toolpath, Offset and Raster.

Calculates an offset area clearance fill pattern to machine inside the selected vector(s). Options for Cut Direction to be either,

Climb (CCW) cutting direction

Conventional (CW) cutting direction

Offset

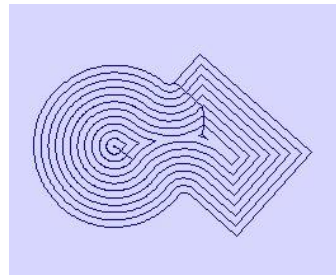

Example of an Offset Fill pattern

Calculates a Raster based area clearance fill pattern to machine inside the selected vector(s) with options for,

Raster



Raster Angle - Between 0 and 90 degrees.

0 degrees is parallel to the X axis

90 degrees parallel to the Y axis.

Profile Pass is used to clean up the inside edge after machining the pocket.

Allowance - can be used to leave material on the inside of the pocket for the Profile Pass to clean-up. This is often very useful for ensuring the cutter does not mark the edge surface of the pocket when roughing out.

Cut Direction to be either,

Climb (CCW) cutting direction

Conventional (CW) cutting direction

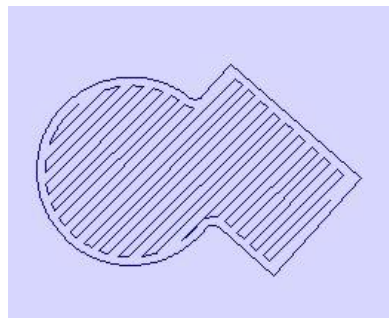

Example of a Raster Fill pattern

Note on offset Pocket Fill

When stepovers greater than 50% of the cutter/tip diameter are used the software automatically adds 'Tail' moves the corner regions on toolpaths to ensure material is not left on the job. You can see these in the diagram of a star being pocket machined below:

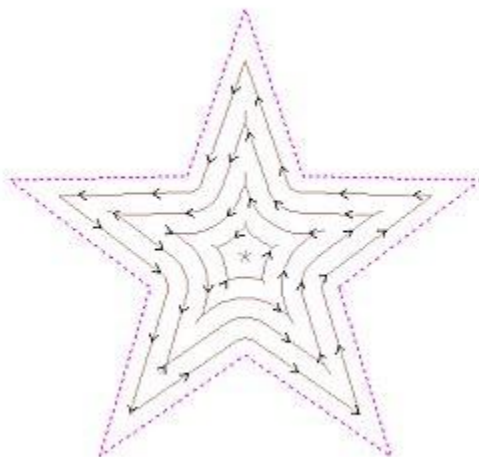

Offset larger than 50%

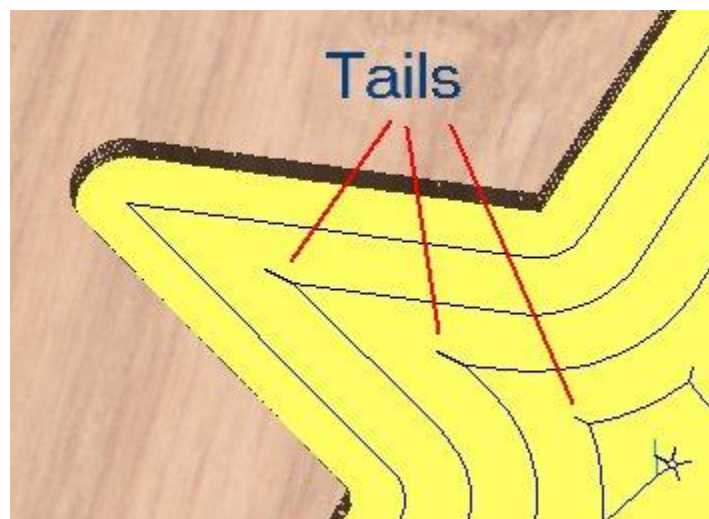

Tails to clean out corners

Cut Direction

Can be set to either Conventional or Climb machining where the cutting direction depends upon the strategy selected - see above for details. Using Climb or Conventional cutting will largely be dictated by the material is being machined. Talk to your material and tooling suppliers for details about what is most appropriate for your specific type of work.

Ramp Plunge Moves

The cutter can be ramped over a distance into the pocket instead of plunging vertically. This approach reduces heat build-up that damages the cutter and also reduces the load on the spindle and z axis bearings.

Safe Z

The height above the job at which it is safe to move the cutter at rapid / max federate. This dimension can be changed by opening the Material Setup form.

Home Position

Position from and to that the tool will travel before and after machining. This dimension can be changed by opening the Material Setup form.

Safe Z

The height above the job at which it is safe to move the cutter at rapid / max feedrate. This dimension can be changed by opening the Material Setup form.

Home Position

Position from and to that the tool will travel before and after machining. This dimension can be changed by opening the Material Setup form.

Name

The name of the toolpath can be entered or the default name can be used.

Drilling Toolpath



Drilling

Drilling allows the centers of selected closed vectors to be drilled to a specified depth. The Tool database includes an option to specify the Drill diameter and cutting parameters.

Clicking on this icon opens the following toolpath form, the functions available within this are described after the image.

Cutting Depths

Start Depth (D)

specifies the depth at which the toolpath is calculated from. When cutting directly into the surface of a job the Start Depth will often be 0.

Cut Depth (C)

The depth of the toolpath relative to the Start Depth.

Tool

Clicking the Select button opens the Tool Database from which the required tool can be selected. See the section on the Tool Database for more information on this. Clicking the Edit button opens the Edit Tool form which allows the cutting parameters for the selected tool to be modified, without changing the master information in the database.

Peck Drilling

When the option for **Peck Drilling** is selected, the drill will cut to the Pass Depth set in the Tool database for the selected Drill. Then retract to the Retract Gap above the surface and then continue drilling to an additional Pass Depth. This cycle is repeated until the hole is drilled to the required depth. The retract moves are used to remove any build-up of material from the hole to help with overheating and breakage. If the Pass Depth is greater than the required Cut Depth, the hole will be drilled in a single cycle. However, if a Cut Depth of 1" with a Pass Depth of 0.25" is used the hole will be drilled in 4 cycles.

Safe Z

The height above the job at which it is safe to move the cutter at rapid / max feedrate. This dimension can be changed by opening the Material Setup form.

Home Position

Position from and to that the tool will travel before and after machining. This dimension can be changed by opening the Material Setup form.

Name

The name of the toolpath can be entered or the default name can be used.

Texturing Toolpath

The 3D Texture Machining functionality uses a specialized toolpath algorithm and the shape of the tool to generate a textured finish on the part. It should be noted this is a different technique than creating a 3D texture using the 3D model.



Texturing Toolpath

Textures can be calculated inside any selected vector boundaries or if nothing is selected the complete job size.

Large Ball nosed cutter and V-Bits typically give the best results when using this strategy.

Clicking on this icon opens the following toolpath form,

Texture Toolpath

Ball Nose (0.5 inch)
Select ... Edit ...

Start Depth (D) 0.0 inches

Use selected vectors as pattern

Texture Settings

Max. Cut Depth 0.2 inches
Min. Depth 0.09"

Max. Cut Length 18.0 inches
Min. Length 6.66"

Max Overlap % 30.0 %
Variation 62 %

Stepover 0.25 inches
Variation ±0.0625"

Angle 0.0 degrees

Save ... Load ...

Safe Z 0.2 inches
Home Position X:0.00 Y:0.00 Z:0.50

Name: Texture 1

Calculate Cancel

The texturing options are based on calculating random patterns and the variables required may at first appear a little complicated. The best way to see what effect each variable has on the texture is to simply change the numbers, calculate and preview the results. It's important to note that the toolpath algorithm uses a random combination of the variables specified on the texturing form to calculate the toolpath.

Tool

Clicking the Select button opens the Tool Database from which the required tool can be selected. Clicking the Edit button opens the Edit Tool form which allows the cutting parameters for the selected tool to be modified, without changing the master information in the database.

Use selected vectors as pattern

By default this option is unchecked and the texture form will generate a random texture pattern using any selected vectors as a clipping area. If this option is checked, the currently selected vectors will be used as the pattern for the texture and the only options available will be 'max. Cut Depth' and 'min. Depth' to control the depth of the cuts along the selected vectors.

Texture Settings

Max. Cut Depth

The maximum depth any of the carved scallops will be machined to and is specified in the job units.

Min. Depth

Using the slider this is specified as a percentage (%) of the Max. Cut Depth and controls the minimum depth any of the scallops will be machined to.

For example, with a Max Cut Depth = 0.200" and a Min Cut Depth of 0.050", the depth of the carved scallops will range randomly between 0.200" and 0.050".

Max. Cut Length

Specifies the maximum length for any of the carved grooves and is specified in the job units.

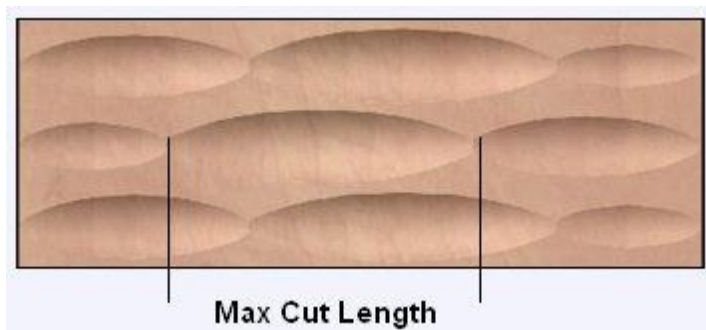

Min Length

Using the Slider this is specified as a percentage of the Max Cut Length and controls the minimum length any of the carved grooves.

For example, with a Max Cut Length = 3" and a Min Length of 0.150", the length of the randomly carved scallops will range randomly between 3" and 1.5" long.

Max. Overlap %

The percentage (%) of the Max Cut Length that each scallop is allowed to overlap the adjacent scallop running along the cutting direction. Where, 1% will result in almost zero overlap of adjacent scallops 50% will result in some of the scallops being machined half way over the adjacent scallop.

Variation

Using the slider this is specified as a percentage of the Max Overlap. Overlap variation of 100% = the Max Overlap and random pattern Overlap variation of 1% = No Overlap and an almost constant pattern.

For example, with a Max Cut Length = 1", Max Overlap = 25% and Overlap Variation = 50%, the random overlap pattern calculated will range between 0.25" and 0.125". **Stepover** specifies the depth at which the toolpath is calculated from. When cutting directly into the surface of a job the Start Depth will often be 0. If machining into the bottom of an existing pocket or 3D region, the depth needs be entered.

Stepover

The distance between each parallel set of lines of carved scallops.

Variation

Using the slider this is the percentage used to randomly change the stepover between each scallop. If a variation of 0% is specified the scallops will all be parallel to each other. And a variation of 50% will result in some scallops overlapping half way over others.

Angle

The direction the texture is machined across the surface, an angle of zero is parallel to the X axis, examples of setting the angle to 45 and 90 degrees can be see below.



45 Degrees

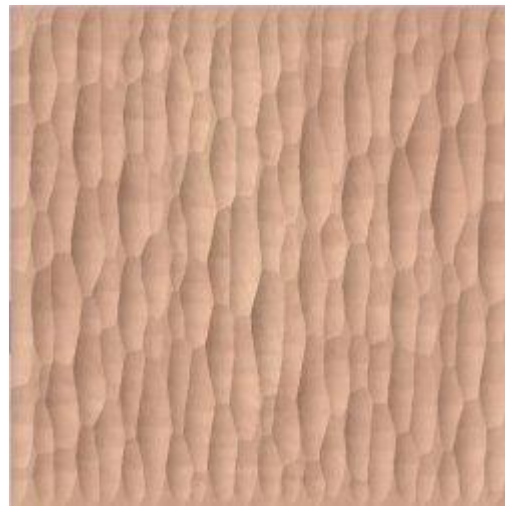

90 Degrees

Safe Z

The height above the job at which it is safe to move the cutter at rapid / max federate. This dimension can be changed by opening the Material Setup form.

Home Position

Position from and to that the tool will travel before and after machining. This dimension can be changed by opening the Material Setup form.

Name

The name of the toolpath can be entered or the default name can be used.

Note on Texture Toolpaths

As Texturing Toolpaths are calculated using a Random combination of the parameters and variable listed on the form the toolpath will change very slightly every time a toolpath is calculated.

Inlay Toolpaths

The Inlay toolpath functionality can be used to calculate either profile or pocketing toolpaths with automatic compensation for the tool radius, this allows the cut-out parts to fit into the corresponding cavities. This is a good feature for creating decorative woodworking and is also particularly useful for sign makers for creating inlayed letters and graphics.



Inlay Toolpaths

Opens the 'Create Inlay Toolpath' form to allow access to the different types of inlay toolpaths which are supported by the software

How Inlays work

When using a CNC machine to cut out shapes then the tool will always leave a radius on any internal corner. When cutting holes or pockets the tool conversely leaves a radius on the external corners. If no changes are made to accommodate this then there would be no way to fit one part into the other. This is shown highlighted on the letter "T" shown in the image below. On the left you can see the internal corners with a radius on the part being cut out (highlighted with red ovals). On the right you can see the radiused external corners on the hole (highlighted with green ovals). As you can envisage trying to slot the "T" into the hole would not work as it is the proverbial square peg in a round hole!

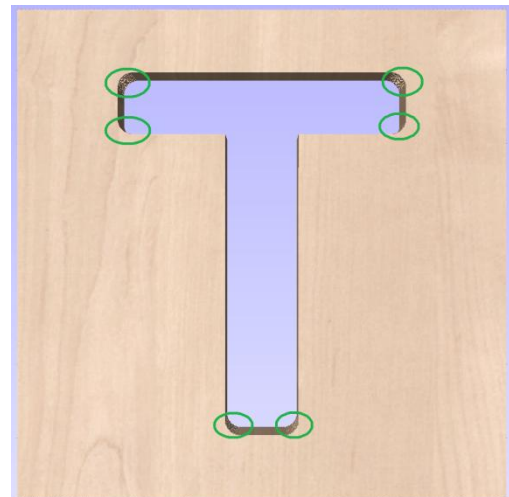
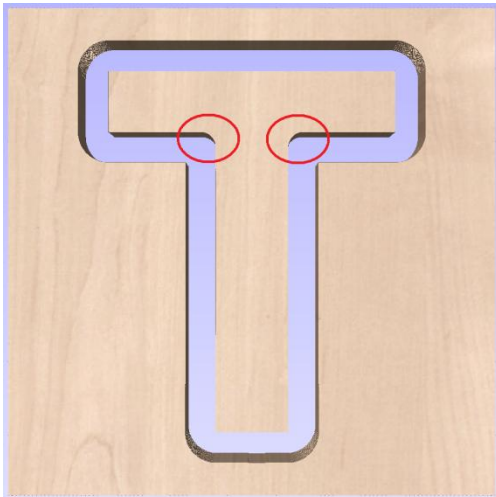

It is not possible to avoid the added radius as it is formed by the tool size and shape. The Inlay function though, will create toolpaths which take the tool radius into account and compensate for it by rounding off the sharp corners so the resulting parts will fit together. This can be seen in the images shown below where the same letter has been cut using the Inlay toolpaths, you can see all corners (internal and external) now have the same radius so they will slot together.

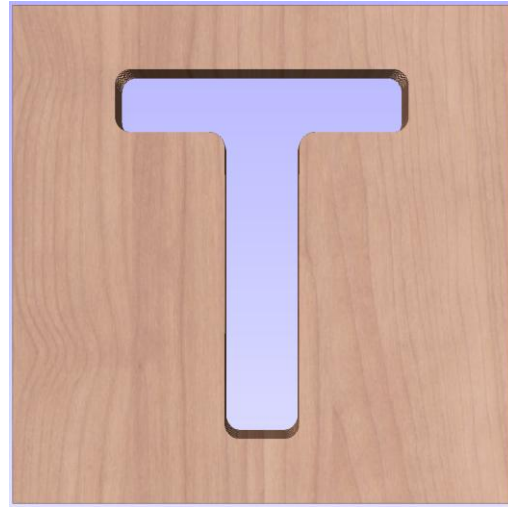
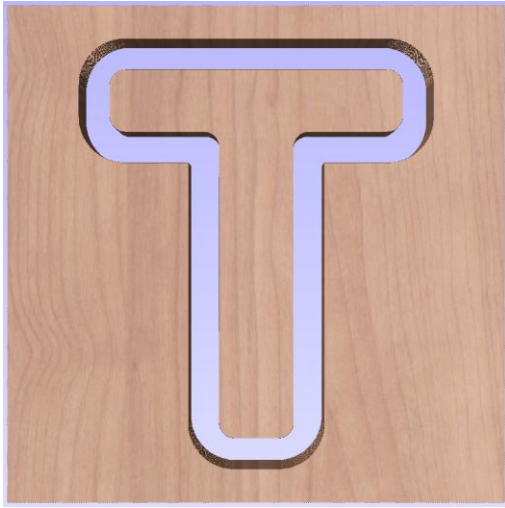

IMPORTANT NOTE: Using the same tool for Inlays

When creating an Inlay toolpath the radius is automatically compensated for, so it is very important to make sure you specify the same tool for both parts of any inlay (male and female). If you do not do this the **Inlay** will not fit together. If creating a **Pocket** then the main **Tool** (the finish tool) not the larger (clearance) tool should be the same as the one as used for creating the **Male Inlay**.

IMPORTANT NOTE: Allowance for Inlays

Although the radius of the tool is compensated for when using the inlay tool, this in itself will almost always not be enough to ensure the two parts will fit together correctly. The parts will be exactly the same size and so would not fit together without a lot of force which would damage the part or without some kind of post-CNC hand work. Cutting the parts exactly the same size also does not allow for any kind of finish to be applied to either side.

To enable the parts to fit extra material either needs to be cut from the **Male** side, the **Female** side or in some applications both. This additional distance is added using the option in the toolpath form to add an Allowance. On the toolpaths which are based on a **Profile** then this is done with the **Allowance Offset** (Shown in the image below left – highlighted with a red box). For **Pocket** style toolpaths use the **Pocket Allowance**, (shown in the image below right highlighted with a red box). When a value is entered it will overcut the selected shape by this distance, this will reduce the size for male parts and increase the hole/pocket for female parts.

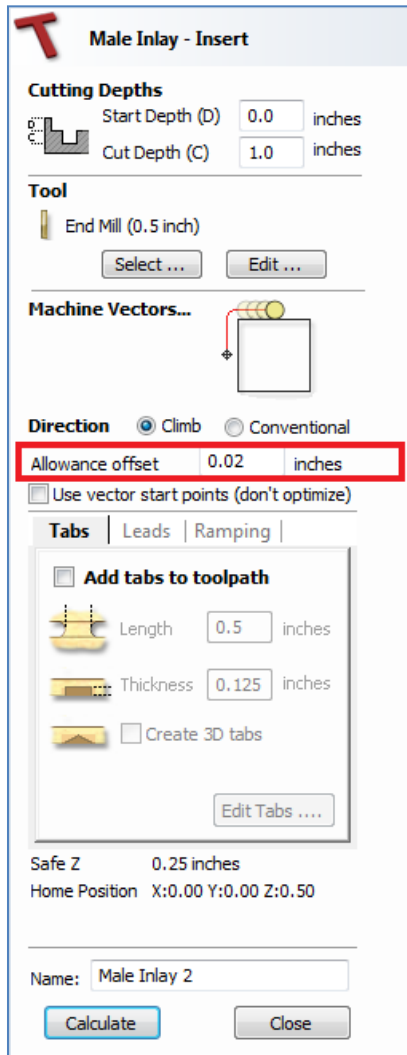

The size of the **Allowance** required will depend on the type of material (how much it may expand or contract between being cut and inlayed), the accuracy of your tooling, the accuracy of your machine and finally any finish you are planning to add to the finished parts (such as paint or varnish which will have a thickness). In most situations where no finish is being applied before the parts are inlayed then an allowance of 0.01” or 0.02” will be sufficient. If you are not sure what value to use then you should experiment with this on a test part to get the correct sizes for your particular setup and application.

In the majority of cases the **Allowance** is applied to the **Female** side of the inlay as it is typical to not want to alter the actual vector shapes (the **Male** side) any more than is required for the tool radius. This means the **Hole** or **Pocket** will be cut over-sized to provide the additional allowance for the parts to fit.

The icon for the **Inlay Toolpath** is located in the **Toolpath Operations** area of the **Toolpaths** menu, this can be seen highlighted with a red box in the image shown below:

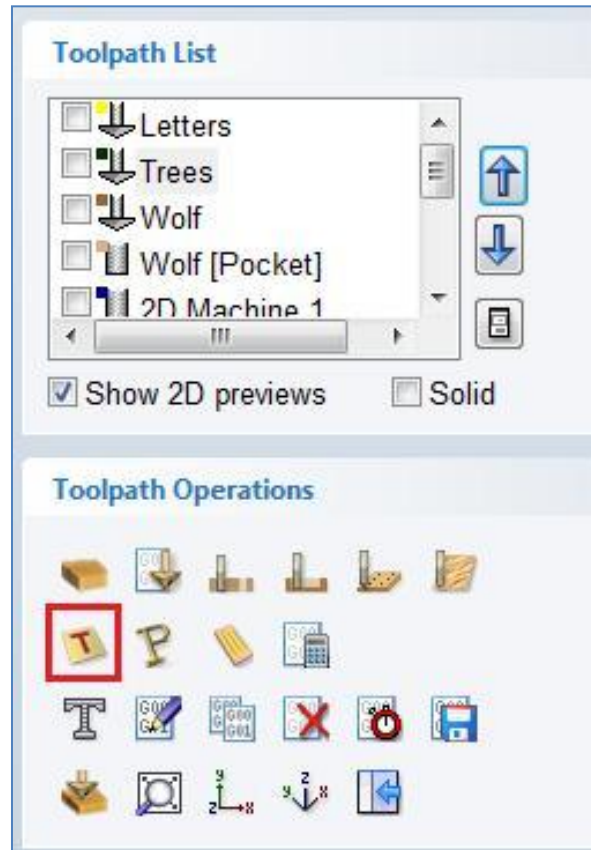

When you click on this the form shown below will appear, you have a choice of four types of **Inlay**, two **Male** and two **Female**.

Both the **Male Inlay** options and the **Female Hole** option use variations on the standard **Profile** toolpath, the **Female Pocket** option uses a variation of the **Pocket** toolpath. In this section we will not document the complete form for each of these but just where they differ from the standard versions of each toolpath form. To learn more about the standard **Profile** and **Pocket** options please see the relevant sections in this **Reference Manual**.

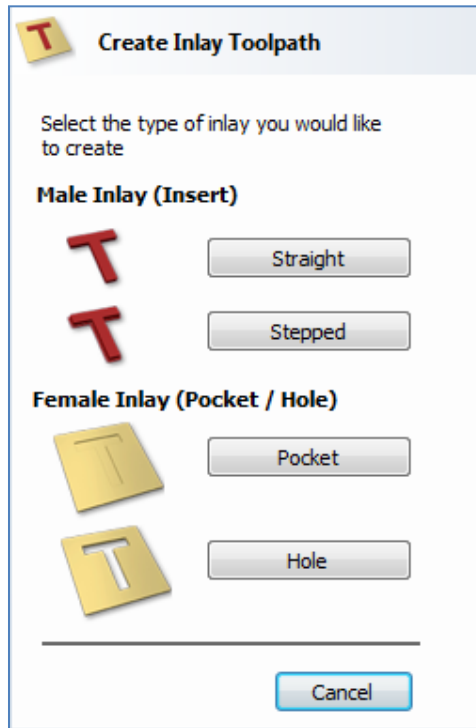

Male Inlay (Insert)

Straight

This option is for cutting out straight sided parts to act as the inserted piece of the inlay. It uses a variation on the **Profile** toolpath which will automatically round the external corners of the part to allow for the radius of the tool being used. All the standard **Profile** options are available in this form except there is no option to **Profile Inside** or **On** as this does not apply to this inlay type as it has to cut outside of the vector. The other standard option not available is the ability to add sharp **Corners** as again this would not apply to this application. Note in the image shown below how the external corners are rounded based on the tool radius being used.

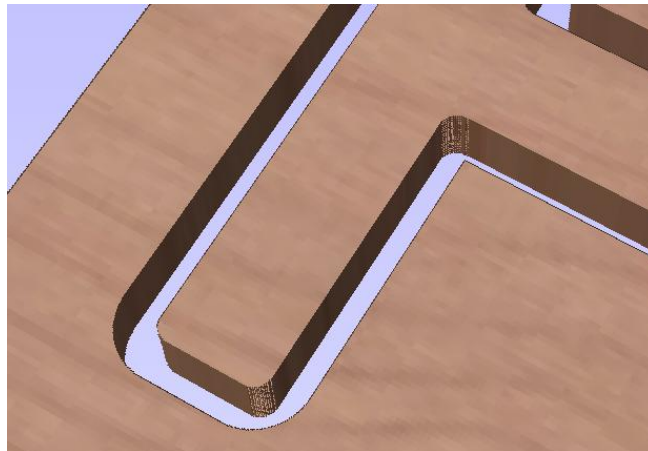

Stepped

This option is for cutting out stepped sided parts to act as the inserted piece of the inlay. This style of inlay is typically used for what are referred to as “Push Through” letters and shapes. These are parts which are inserted from the back and use the step as a shelf to invisibly mount them to the back of a sign. As with the **Straight Inlay** option it uses a variation on the **Profile** toolpath with the addition of the ability to specify a **Step Depth** and **Step Width**. These are defined in the area of the form highlighted with a red box in the image below:

Stepped Male Inlay - Insert

Cutting Depths

Start Depth (D) 0.0 inches

Cut Depth (C) 0.5 inches

Tool

End Mill (0.25 inch)

Select ... Edit ...

Step Depth (d) 0.25

Step Width (w) 0.15

Direction Climb Conventional

Allowance offset 0.0 inches

Use vector start points (don't optimize)

Tabs | Ramping |

Add tabs to toolpath

Length 0.5 inches

Thickness 0.125 inches

Create 3D tabs

Edit Tabs ...

Safe Z 0.25 inches

Home Position X:0.00 Y:0.00 Z:0.50

Name: Stepped Male Inlay 1

Calculate Close

As the diagram shows in the form the **Step Depth** is the vertical height of the step from the **Start Depth** down, the **Step Width** is how far from the edge of the original vector the part will be cut out (creating the step).



The image shown above shows a Stepped Male Inlay created in 1 inch thick material with a **0.75” Step Depth** and a **0.3” Step Width**.

All the other standard **Profile** options are available for **Stepped Inlays** except there is no option to **Profile Inside** or **On** as this does not apply to this inlay type and this option does not allow the use of either the **Corner** or **Lead** functions as these are also inapplicable to this type of toolpath.

IMPORTANT NOTE on Stepped Inlay Spacing

It is very important when working with **Stepped Inlays** that you allow enough space in between the shapes you are cutting out for the **Step Width** to be added. If the parts are too close then they will not be cut-out and the steps will not be properly formed.

Female Inlay (Pocket / Hole)

Pocket

This option is selected for cutting out a **Pocket** to act as the cavity for the corresponding **Male** shape to inlay into. It uses the same options as the standard **Pocket** style toolpath including the new option where you can use a larger and smaller tool to clear the pocket (smaller tool size should match that used for the Male Inlay). In order to make it work as an inlay pocket any internal corners will be rounded based on the tool radius to allow the male parts to fit into them (shown in the image below).

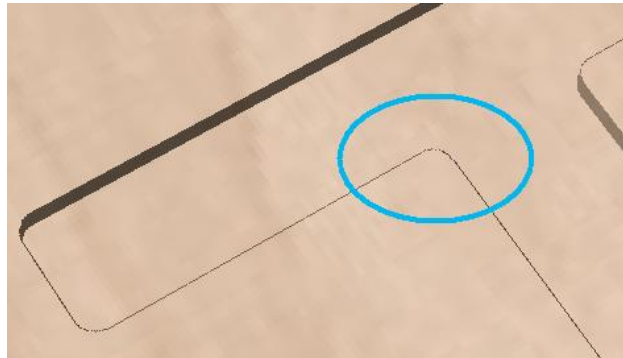

As has been previously discussed it is common to leave an allowance on one or both sides of the inlay, typically when working with letters the allowance would be left on the **Pocket** so the size and shape of the lettering itself is not affected any more than necessary.

Hole

This option is for cutting out a **Hole** to act as the cavity for the corresponding **Male** shape to inlay through. The standard **Profile** options are available for **Female Hole Inlays** except there is no option to **Profile Outside** or **On** as this does not apply to this toolpath type and this option does not allow the use of the **Corner** options as these are also inapplicable to this type of toolpath. In order to make it work as an inlay, any internal corners will be rounded based on the tool radius to allow the male parts to fit into them (shown in the image below).

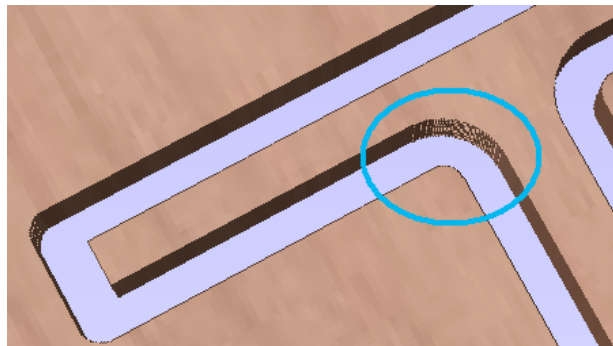

As has been previously discussed it is common to leave an allowance on one or both sides of the inlay, typically when working with letters the allowance would be left on the **Hole** so the size and shape of the lettering itself is not affected any more than necessary.

Prism Carving Toolpath



Prism Carving Toolpath

Prism carving gives a raised 'bevel' effect to shapes and letters similar to a 'hand carved' look.

Prism Carving uses an angled tool to create a raised prism shape on the top of the selected vectors. The tool will profile at a given depth creating a nice sharp finished shape such as the lettering shown in the image below. This is often paired with a **Profile** or **Pocket** toolpath to carve the vertical edge around the shapes or clear out the material between them. This type of toolpath is often though not exclusively used on lettering.



The **Prism Carving** option can be found on the **Toolpaths** menu under **Toolpath Operations** area, the icon is shown in the image below highlighted with a red box.

Clicking this icon will open the **Prism Carving Toolpath form** shown in the image below.

Prism Carving Toolpath

Cutting Depths

Start Depth (D) 0.0 inches

Prism Depth 0.5823 inches

Set Depth for Full Prism

Tool

V-Bit (90 deg 1.25")

Select ... Edit ...

Direction Climb Conventional

Safe Z 0.25 inches

Home Position X:0.00 Y:0.00 Z:0.50

Name: Prism Carve 1

Calculate Close

Cutting Depths

Start Depth (D)

Start Depth (D) specifies the depth at which the **Prism Carving** toolpath is calculated from. When cutting directly into the surface of a job the **Start Depth** will often be Z0. If machining into the bottom of an existing pocket or stepped region, the depth of the pocket/step that you are starting from must be entered here.

Prism Depth

This sets the depth of the **Prism Carving** toolpath relative to the **Start Depth**, the total depth of the base of the prism shape (within the material) will be the combination of the **Start** and **Flute Depth**. This depth is particularly important to set correctly as if it is too shallow then the prism shape may be truncated so it will have a flat top (shown in the image below right). The minimum depth needed to avoid this is determined by the widest point on the vector/s selected (W) and the angle of the tool (A). This can be calculated automatically by using the **Set Depth for Full Prism** function (see below for more details).

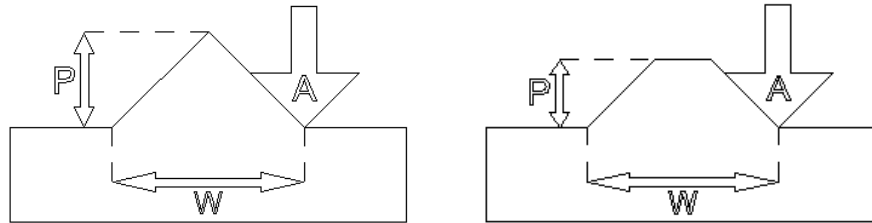

Set Depth for Full Prism

For this button to work you both need to select the vectors you plan to toolpath and also have selected the tool you are going to use, then when you click it the **Prism Depth** will be set to the minimum required to ensure a full point on the prism for the current selection/tool.

Tool

Clicking the **Select** button opens the **Tool Database** from which the required tool can be selected. See the section on the **Tool Database** for more information on this. Clicking the **Edit** button opens the **Edit Tool** form which allows the cutting parameters for the selected tool to be modified, without changing the master information in the database.

IMPORTANT NOTE: Tooling size and quality for Prism Carving

Prism Carving is predominantly cut using a V-shaped cutter, having sharp tooling which is accurately sized is very important to getting good results. You should measure your cutters to make sure the size and angle of the v-bit are as per the manufacturers specifications as a variation of even 1 or 2 degrees on the angle can make a big difference to the quality and precision of **Prism** carved shapes.

Direction

Can be set to either Conventional or Climb machining, the choice for this will largely be dictated by the material being machined and type of tool being used. See the section on Profile Toolpaths in the Reference Manual for more information on the differences between these.

Safe Z

The **Safe Z** value defined the distance above the job at which it is safe to move the cutter at rapid/max feedrate. This dimension can be changed by opening the **Material Setup** form.

Home Position

This is the position that the tool will travel to before and after machining. This dimension can be changed by opening the **Material Setup** form.

Name

A name for the **Prism Carving** toolpath can be entered or the default name can be used.

Fluting Toolpath



Fluting Toolpath

Fluting Toolpaths are used to machine along vectors while varying the depth of the tool.

This toolpath is similar to the option to **Profile “On”** a selected vector. The difference is the toolpath at the end of each vector can be ramped to taper the cut. This can be used for cutting standard woodworking “Flutes” or can be used for artistic engraving and marking effects with other types of artwork. In this section the options on the form will be covered along with some examples of the use of this for different applications.

When you click on this icon the form shown below will appear.

Fluting Toolpath

Cutting Depths

Start Depth (D) 0.0 inches

Flute Depth 0.75 inches

Tool

Ball Nose (0.75 inch)

Select ... Edit ...

Flute Type

Ramp over complete length

Ramp at Start

Ramp at Start and End

Ramp Length 0.0 inches

Ramp % 100 %

Ramp Type

Linear

Smooth

Safe Z 0.25 inches

Home Position X:0.00 Y:0.00 Z:0.25

Name: Fluting 1

Calculate Close

When the **Fluting Toolpath** is chosen the selected vectors will have their start points indicated in the **2D View** by solid square green nodes, this is important as it will determine which end the ramps are added depending on what modifying options are chosen from the form. An image of this is shown below where all the start points are to the left end of the selected vectors.

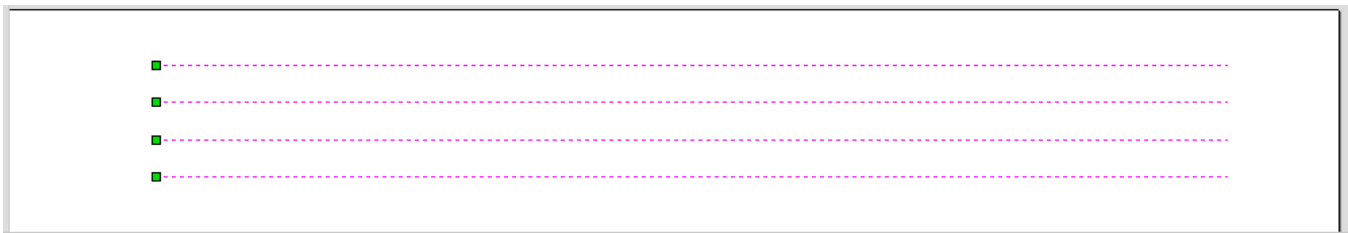

If you need to move the start points, go into node editing mode (press 'N' on the keyboard or select the node editing icon in the 'Edit Vectors' section on the left tab).

- 1) Select the vector you want to change the start point
- 2) Move the cursor over the end you want to be the new start point
- 3) Press 'P' on the keyboard or Right Click and select 'Make Start Point' from the pop-up menu.
- 4) Exit node edit mode (press 'N' again)
- 5) Reselect all the vectors you want to flute

The fields on the form are as follows.

Cutting Depths

Start Depth (D)

Start Depth (D) specifies the depth at which the **Fluting** toolpath is calculated. When cutting directly into the surface of a job the **Start Depth** will often be 0. If machining into the bottom of an existing pocket or stepped region, the depth of the pocket/step that you are starting from must be entered.

Flute Depth

This is the depth of the **Fluting** toolpath relative to the **Start Depth**; the total depth will be the combination of the **Start** and **Flute Depth**.

Tool

Clicking the **Select** button opens the **Tool Database** from which the required tool can be selected. See the section on the **Tool Database** for more information on this. Clicking the **Edit** button opens the **Edit Tool** form which allows the cutting parameters for the selected tool to be modified, without changing the master information in the database.

Flute Type

Ramp over complete length

Checking this option means the tool will ramp over the whole length of the toolpath. At the start of the selected vectors/s it will be at the **Start Depth** and at the end of the selected vectors/s it will have cut down to the **Fluting Depth**.

Ramp at Start

Checking this option means the tool will ramp down only at the start of the vectors to the **Fluting Depth**. The distance of this ramp can be specified using the **Ramp Length** or **Ramp %** options.

Ramp at Start and End

Checking this option means the tool will ramp down at the start of the vectors then will ramp up again at the end of the vectors. The distance of these ramps can be specified using the **Ramp Length** or **Ramp %** options.

Ramp Length

Checking this option means that the length of the ramp can be specified by a specific distance entered into the box. The ramp distance is measured from the start and the end of the vector/s depending what **Flute Type** you have selected. If the distance entered is greater than the possible length of the ramp then the maximum length will be used, this would be the same as choosing **Ramp over complete length**.

When you choose **Ramp at Start** it is possible to specify a ramp length which is up to the length of the vector/s. When **Ramp at Start and End** is checked, the maximum length possible would be half way along the vector/s as after that it would start to ramp up again.

Ramp %

Checking this option means that the length of the ramp can be specified as a percentage of the maximum possible ramp length (controlled by the length of the selected vector/s and chosen **Flute Type**). When you use this with **Ramp at Start** selected then 100% would be the whole length of the selected vector/s, the ramp length would be a percentage of this distance for each one. When you use this with **Ramp at Start and End** then 100% would be the half length of any of the selected vector/s. The ramp length would be a percentage of this “half” length. In this situation using a 50% value would give you a **Ramp** from the start which was $\frac{1}{4}$ of the vector length and a ramp from the end which was also $\frac{1}{4}$ of the vector length.

Ramp Type

Linear

Selecting the **Linear** type will create a ramp which is a diagonal line (following the vector) from the **Start Depth** to the **Flute Depth**. Below you can see a Linear **Ramp Type** shown from the side. This ramp is set to only ramp from the start and to go 50% of the flute length.



Smooth

Selecting the **Smooth** type will create a curved ramp (following the vector) from the **Start Depth** to the **Flute Depth**; this will smoothly transition from the ramp into the full depth of cut. You can see an example of this shown in the image below.

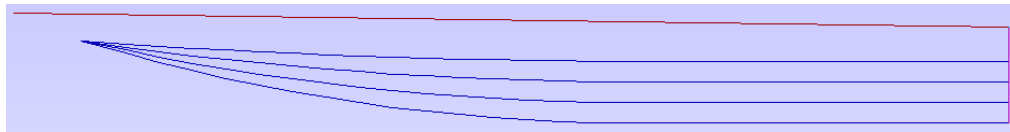

NOTE: Affects of the Pass Depth on Ramps

Note in the two images shown above how there are multiple passes to get to full depth. These occur when the **Flute Depth** exceeds the **Pass Depth** specified for the selected tool. In these cases the tool will make multiple passes no deeper than the **Pass Depth** of the tool. As you can see from the images the ramps are graduated based on how many passes are needed. This ensures that the final pass will always be cutting material along its full length to give a nice even finish on the part.

Safe Z

The **Safe Z** value defined the distance above the job at which it is safe to move the cutter at rapid/max feedrate. This dimension can be changed by opening the Material Setup form.

Home Position

This is the position that the tool will travel to before and after machining. This dimension can be changed by opening the **Material Setup** form.

Name

A name for the Fluting toolpath can be entered or the default name can be used.

Applications for Fluting Toolpaths

Standard Straight Flutes

One of the most common applications for Fluting is straight decorative details using a large radius Ball nose tool for columns and posts, such as the one shown in the image below.

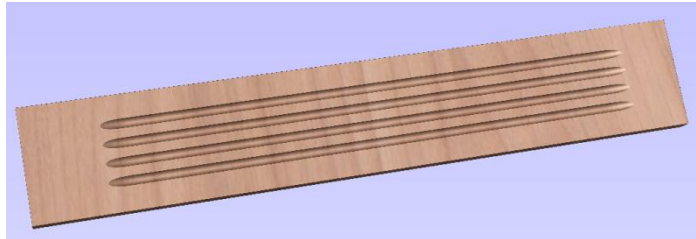

Another good application for straight flutes is the markings on a draining board (for Solid Surface fabricators) or on a cutting block (for carving meat) such as the one shown below, sloping down to allow liquid to be directed.



Decorative Artistic Designs

The fluting can be used to produce some interesting effects with artistic and decorative applications. The abstract leaf pattern below was cut with a V-Bit into a flat surface using single vector lines.



Quick Engraving Toolpath



Quick Engrave

This form is used specifically for calculating engraving and marking toolpaths.

Clicking on this icon opens the following toolpath form, the functions available within this are described after the image.

Quick Engrave

Tool
Engrave (20' 0.02" Tip Dia)
Select ... Edit ...

Depth / Pressure 0.0 inches

Outline **Fill**

Stepover 0.0 inches

Offset **Hatch**
Hatch Angle
0.0 degrees
 Cross Hatch

Use Nose Cone
Tool Depth 0.02 inches
Number of Passes 1

Safe Z 0.25 inches
Home Position X:0.00 Y:0.00 Z:0.50

Name: Quick Engrave 1
Calculate

Post Processor
Roland (mm) (*.rol) v
 Output direct to machine
Driver: ...

Save Toolpath(s) ...
Close

Tool

Clicking the Select button opens the Tool Database from which the required tool can be selected. See the section on the Tool Database for more information on this. Clicking the Edit button opens the Edit Tool form which allows the cutting parameters for the selected tool to be modified, without changing the master information in the database.

Depth / Pressure

When using **Conventional Engraving and End Mill** cutters the **Depth** to engrave / mark is specified and this z depth dimension is output in the toolpath file sent to the CNC machine. The 3D Preview of these toolpaths shows the specified depth of engraving.

When using a **Diamond Drag marking Tool** the **Pressure** setting is used to pre-load the spring to ensure the tip of the diamond stays in contact with the material surface, especially when marking uneven surfaces. The 3D Preview of the depth these toolpaths will mark using the Angle of the diamond and the Width of the Line.

For example; When using a 90 degree Diamond Drag Tool with a 0.010" Line Width specified. The depth shown in the 3D preview will be 0.005" (with 90 degrees the depth = half the line width).

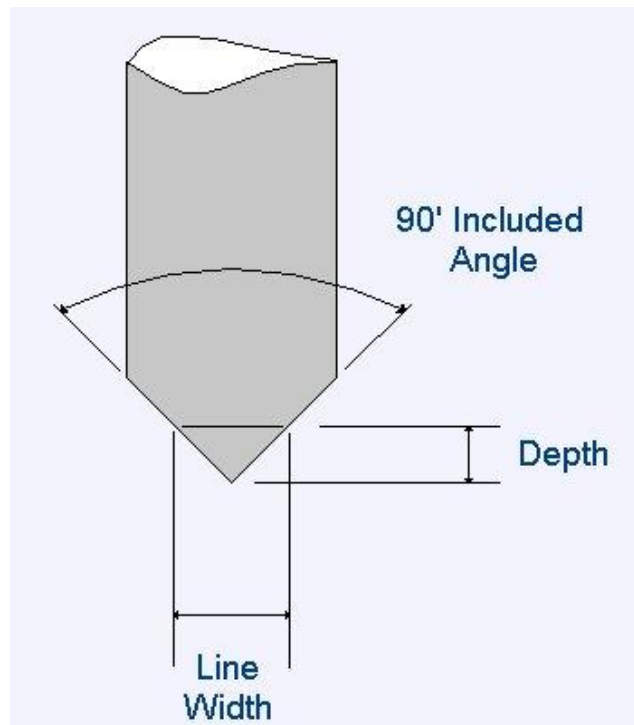

The ratio of Depth to Line Width will change when using diamond drag tools with different tip angles. When the option to use a Nose Cone is selected (see below) the actual depth specified on the form is used when previewing the toolpath in the 3D view.

Strategy

When using the Quick Engraving Form the Stepper for the cutter is specified on the form and is NOT automatically set from the tool database.

The selected text or vectors can be **Outlined** or **Filled**.

Outline

The tip of the cutter runs on the selected lines engraving / marking the material surface



Example of outline engraving

Filled

A pattern is used to engrave / mark inside the selected text or vectors. There are 3 fill pattern options.



Fill engraving with Offset pattern



Fill engraving with 45 degree Hatch pattern



Fill engraving with Cross Hatch pattern

Cross Hatch Fill pattern engraves 2 sets of lines, with the second set at 90 degrees to the angle specified.

Use Nose Cone

A nose cone is often used when engraving or marking material that is not flat. The nose cone is spring loaded forcing it to slide on the surface of the material. The engraving cutter is set to extend / protrude out of the bottom of the nose cone by the depth of engraving / marking required. This is typically set at around 0.010" to 0.020".

When the option to use a Nose Cone is selected the actual depth specified on this region of form is used when previewing the toolpath in the 3D view.

Number of Passes - This option runs the cutter multiple times divides over the toolpath pattern.

Output Options

Select the appropriate postprocessor and Save the Toolpath ready to send to the CNC machine.

If your machine can be driven using a Windows Printer driver (Roland and Gravograph / New Hermes machines use this technique) it may be possible to select the installed printer driver and output toolpaths directly from the software instead of saving an intermediate file.

Checking the option Output direct to machine enables the Device option which is used to setup the appropriate windows printer driver.

This option is used to modify an existing toolpath.



Edit Toolpath

1. Click to select a toolpath in the list then click the edit option to open the form.
2. The vectors associated with each toolpath are automatically remembered, so editing a toolpath will automatically select the vectors in the 2D window.
3. Make the required changes to the toolpath parameters
4. Click the Calculate button to update the toolpath

A toolpath can also be edited by **Double clicking** on the name in the toolpath list.

The Copy Toolpath option creates a copy of the selected toolpath and adds a suffix to the name of the new toolpath. For example,



Copy Toolpath

Cut out - 1/4 " End Mill will create a copy with the name **Cut out - 1/4" End Mill (1)**

Copying 3D toolpaths from PhotoVCarve will also create a duplicate grayscale thumbnail image in the 2D window, which can then be used to move or position the toolpath.



Delete Toolpath

This option is used to delete calculated toolpaths from the display list. Simply select the toolpath to be deleted and click the Delete Toolpath option.

Important - Ensure the correct toolpath is selected as there is no option to confirm before deleting and this cannot be undone.



Estimated Machining Times

This option estimates the machining times for all calculated toolpaths based on the feed rates specified for each tool. The estimates for individual toolpaths plus the overall machining time are calculated using the user defined Rapid Rate moves and Scale Factor.

Clicking this icon will open the following form:

Estimated Machining Time

Total machining time
00:07:51

Individual machining times

V-Carve Toolpath 1
00:05:44

V-Carve Toolpath 2
00:01:05

Profile Toolpath 1
00:01:02

Time estimates based on

Rapid Rate inches/sec
Scale Factor

Times

The estimated machining times are displayed in Hours : Minutes : Seconds

Rapid Rate

The maximum feedrate at which the machine runs for rapid moves, typically specified using G0 or G00 moves

Scale Factor

The nature of different styles of toolpaths means that they may be simple 2D cuts or require simultaneous 3-axis moves, the more complex the toolpath then the more chance the CNC machine may not actually achieve the programmed feed rates. This can be

compensated for by multiplying the times by the Scale Factor. This value just multiplies the time calculated based on the specified feeds and speeds. Over time as you learn how your machine performs (by timing it and comparing to the estimate) then this value can be tweaked to get more accurate estimates.

Note

The information displayed on the form for each toolpath can be selected, copied and pasted into another document.

Saving Toolpaths



Save Toolpath

This option allows toolpaths to be saved in the appropriate file format needed to drive the CNC machine. Toolpaths can be saved as individual files for each tool used or as single file containing multiple toolpaths for CNC machines that have automatic tool changers.

Individual Toolpaths CNC machines that require the tooling to be changed manually will typically need a separate toolpath for each cutter used. The procedure for saving this type of toolpath from VCarve Pro is to;

1. Select the toolpath to save from the Toolpath List
2. Click on the Save option and the Save Toolpaths form is displayed as shown below:



3. Select the correct **Postprocessor** for the CNC machine from the pull-down list
4. Click the **Save Toolpath(s)** button
5. Enter a suitable **Name** and click the **Save** button

Note: When multiple toolpaths are created using the same tool geometry and tool number, they can be saved into a single file by selecting the option to - **Output all visible toolpaths to one file.**

Automatic Tool Changing Support

CNC Machines that have Automatic Tool Changing (ATC) capabilities can work with a single file that contains multiple toolpaths, each having a different tool number.

The postprocessor must be configured to support ATC commands for your CNC machine. Contact your software or machine supplier for more details.

The procedure for saving these toolpaths is,

1. Use the Up & Down arrows to order the toolpath list in the cutting sequence required.
2. Tick each toolpath to ensure it is drawn / visible in the 3D window as shown in the image shown below:



3. Click on the **Save** option and the Save Toolpaths form is displayed.
4. Select the option to – **Output all visible toolpaths to one file**



The names of the toolpaths that will be written into the file are displayed along with the tool number in square brackets [1]. If a calculated toolpath is not required, simply tick to undraw it.

5. Click the Save Toolpath(s) button
6. Enter a suitable Name and click the Save button

Error Messages

The postprocessor automatically checks to ensure,

1. It has been configured for saving files that include ATC commands
2. A different tool number has been defined for each different cutter being used.

An error message will be displayed to indicated the problem if either of these items is not correct.

Previewing Toolpaths



Preview Toolpath

Calculated toolpaths can be previewed to see exactly what they will produce when cut into the material. The 3D preview mode also allows the job to be viewed in different material types with the option to paint the machined regions with a Fill Color.

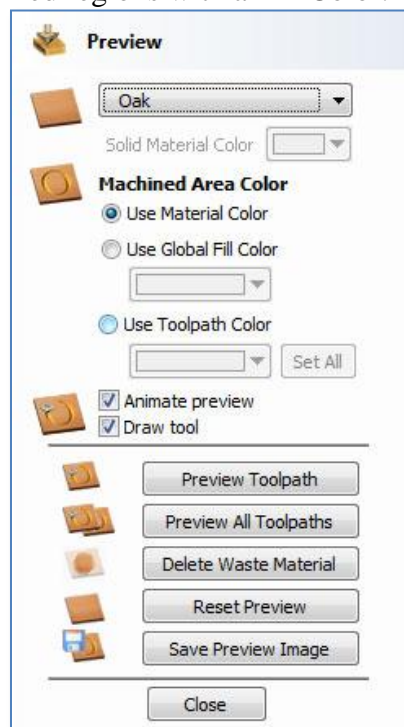

Material

The pull-down list offers a range of material types to shade the 3D model. The first entry in the list is 'Use Solid Color' and if this is selected the color for the material can be selected from the color picker form.

See Adding Custom Materials below for adding your own materials.

Use Global Fill Color

Paint **ALL** the machined regions with the selected color. Selecting the pull-down list opens the default color selection form.



Clicking the **More Colors** option allows custom colour's to be selected

Use Toolpath Color

If this option is selected each toolpath can have a different color assigned. If the 'No Fill' option is selected from the color picker form, the current toolpath will be shown in the material color.

Animate preview

Option to show the material being removed by the cutter as the preview is drawn.

Draw tool

Option to show a wireframe animation of the tool (to scale) cutting the job.

Preview Toolpath

Animates the selected toolpath cutting into the material

Preview All Toolpaths

Animates all calculated toolpaths cutting into the material

Delete Waste Material

If a profile toolpath is calculated the excess material around the edges of the job can be automatically removed to show the finished job.

Reset Preview

Resets the material back to a solid block

Save Preview

Saves an image of the 3D window as a BMP, JPG or GIF file

Note: Saving the image without the Colour Shaded Background is often useful when the image will be used on its own in a brochure or on a web site etc.

Adding Custom Materials

Additional materials can be added to the library list by simply copying a image file (JPG, BMP or TIF) of the material or image you wish to render the job with into the folder,

/Program files/VCarve Pro/Textures/1_Wood etc.

A custom folder that includes shading materials can also be added by simply creating a folder in the Textures folder as shown below.

/Program files/VCarve Pro/Textures/5_My_Shading_Textures

Note: VCarve Pro must be restarted when new materials are added.

Shading textures can be obtained from sources such as the internet, clipart libraries or simply create your own from a digital or scanned photographs. For good quality results the image needs to be approximately 1000 pixels x 1000 pixels. The texture image is simply scaled proportionally in X & Y to fit the longest side of the job.

Multi-Colored Toolpath Preview

When previewing the effects of each toolpath it is possible to assign different colors to each one. This can be used to simulate the effects of differently painted areas both as a way to verify what is being cut by the toolpaths and also to provide an image than can be emailed or printed for customer approval. An example of the new shading in use is shown in the image below of the Howling Wolf Sign, with the new preview on the left and the actual finished sign on the right.



The different colors can be set from the **Preview Toolpath** form – this appears automatically when a toolpath is calculated or can be accessed anytime by clicking the icon under the **Toolpath Operations** area of the **Toolpath** menu, shown below, highlighted by a red box.

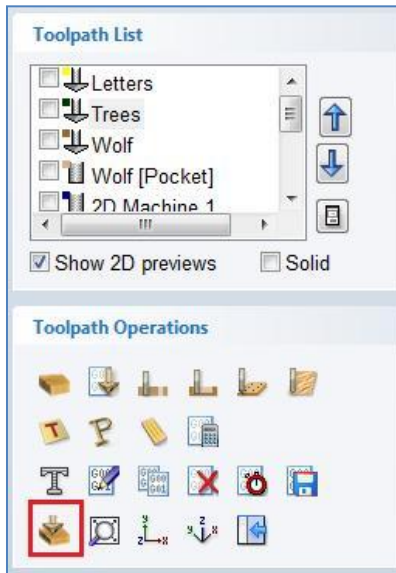

When this icon is clicked (or immediately after a toolpath is calculated) then the **Preview** form will be shown. The options for defining the fill color are contained in the **Machined Area Color** area of the form highlighted with a red box in the image below.

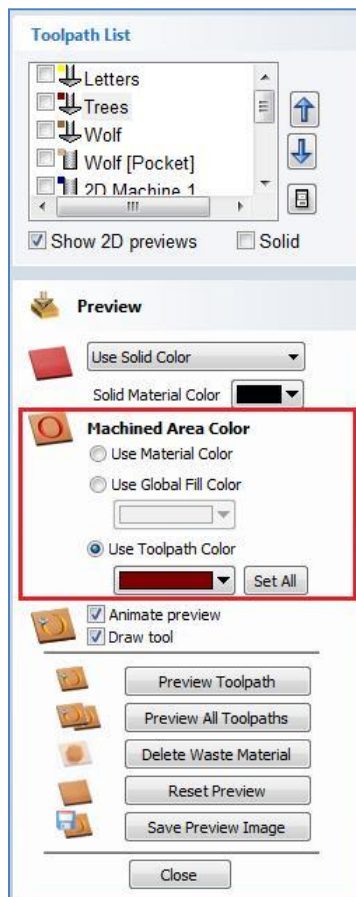

IMPORTANT NOTE: Solid Material Color

Before the individual toolpath color fill is covered it is worth pointing out another feature within the preview form. There is the option at the very top of the **Material List** to select a **Solid Color** for the surface of the part. Once this is selected the color choice can be made from the drop-down **Solid Material Color** area. This allows material with a different solid color surface and core to be easily represented. The **Use Solid Color** option is shown in the image below:

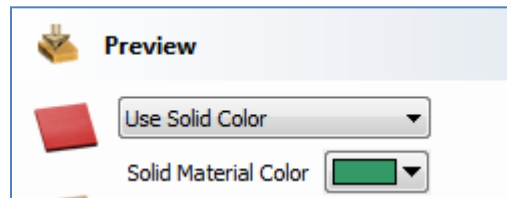

Machined Area Color

Use Material Color

Checking this option will use the same color/material for the fill as you have selected for the material itself as shown in the image below.



Use Global Fill Color

Checking this will use the same single fill color for all toolpaths as shown in the image below.



Use Toolpath Color

Checking this will let you select different colors for each toolpath in your list as shown in the image shown below.



To set the color individually, first select the toolpath from the **Toolpath List** and then click on the drop down arrow next to the color block to show the form shown below:

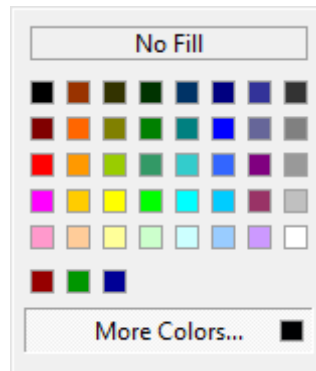

Choose the color you want for the fill of that toolpath and it will be applied to the areas that the toolpath has carved when they are previewed. Once you assign an individual color a small square of that color will be displayed next to the name in the toolpath list. This can be seen in the image shown below just to the left of each tool icon.

If you click the option at the top of this form where it says “**No Fill**” then this will leave that toolpath in the selected Preview Material Color.

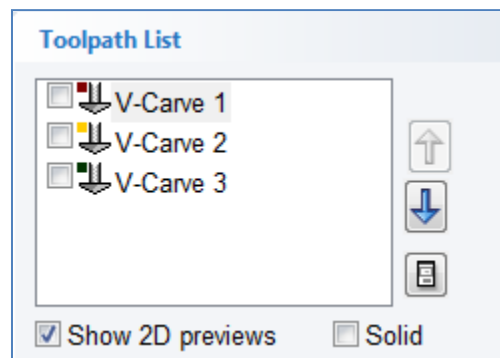

Set All

Clicking the **Set All** button will set all the toolpaths in your **Toolpath List** to the currently selected color. **ONLY** click this if you want to change all toolpaths to have the same color as you cannot undo this operation.



Zoom to Fit Zooms the view to fit everything in the 3D View window so it fits the size the Window is currently set to.

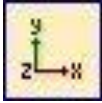

Plan View Selecting Plan View looks directly down the Z axis onto the job in the 3D window.



Isometric View Displays the job and associated toolpaths in an isometric position and zooms to fit into the 3D window.



Switch to Drawing Tab Closes the Toolpath Tab (right hand screen form) and opens the Drawing Tab (left hand drawing form)

When a toolpath is selected from the Toolpath list with no other function being used in the Toolpath Tab then a summary of the toolpaths settings is shown in the body of the Toolpath Tab below the icons as shown in the image below. This is a useful way to recall settings for a toolpath without opening it.

Tool: Ball Nose (0.125 inch)
Tool No.: 1
Feed: 100.0 inches/min
Plunge: 30.0 inches/min
Spindle: 12000 r.p.m
Home Pos: 0,0,0.5
Safe Z: 0.25 inches
Min. Z: -1.0853 inches
Est. Time: 00:15:03
Max. Depth: 1.0853 inches

Wrapped Rotary Output

Flat toolpaths can be ‘wrapped’ around a cylinder and cut on a rotary axis as shown in the image below.

Please Note: This feature does **NOT** allow the rotary machining of full 3D models

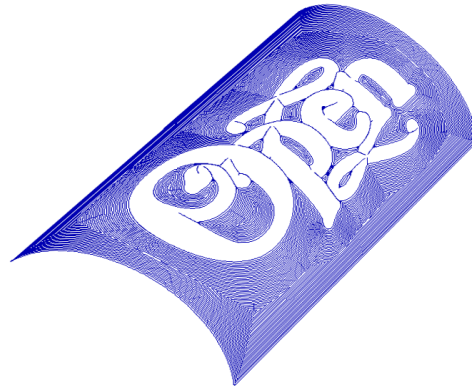

The wrapping support comes in two parts.

- 1) Support in the program for drawing toolpaths wrapped around either the X or Y axis.
- 2) A special post-processor configured for each machine which performs the actual wrapping of the toolpaths ready for sending to the machine.

In addition, Vectric supply a number of ‘gadgets’ which simplify the setting up of the initial job and also performing some common rotary machining operations.

It is important to realize that there are a huge number of possible combinations of machine controller and axis orientations for rotary axis / indexers. This means it is impractical for Vectric to supply a pre-configured post-processor for every possible combination as standard. To avoid confusion for the vast majority of our users without a rotary axis, we don’t include any of the wrapping post-processors in the default post-processor list as standard. However, we have shipped a number of the more common post-processors in the following folder ..

C:\Program Files\VCarve Pro V5.5\PostP\05-Wrapped

If you want to use one of these posts, you will need to copy it to the C:\Program Files\VCarve Pro V5.5\PostP folder and restart the program. If Vectric have not supplied as standard a post for your machine configuration please refer to the ‘Post Processor Editing Guide’ accessible from the start of the program help file for information on how to configure a post-processor and look at the sample rotary posts Vectric supply. You should also look at the Vectric forum (www.vectric.com/forum) to see if anyone else has already configured a post for your configuration or one similar. If, after looking at these resources you are still unsure of what needs to be done for your machine, please feel free to contact support@vectric.com for help. However, please note that we cannot guarantee to write a custom rotary post-processor for every individual requirement.

Creating a Wrapped Toolpath – Step by Step

- 1) Ensure you have a ‘wrapping’ post processor for your controller and axis configuration installed in the PostP folder (see above).
- 2) Start a new job using the “Wrapped Job Setup” gadget – This must be run without a file open. When you start the program, before opening a file, click ‘Gadgets – Wrapping – Wrapped Job Setup’ from the main menu bar.

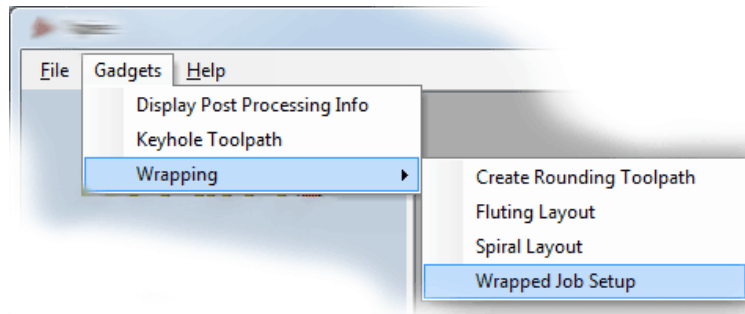

- 3) The ‘Wrapped Job Setup’ form shown below will appear...

A screenshot of the 'Wrapped Job Setup' dialog box. The title bar reads 'Wrapped Job Setup' and 'Version 1.0'. The main text says 'This gadget creates a new blank file laid out for wrapped machining'. Under 'Cylinder Dimensions', 'Cylinder Length (L)' is 48 units and 'Cylinder Diameter (D)' is 8 units. 'Units' are set to 'inches'. Under 'Cylinder Orientation Along ...', 'X Axis (wrap Y values)' is selected. Under 'XY Drawing Origin', the top-left origin is selected. Under 'Z Origin On ..', 'Cylinder Axis (Bottom)' is selected. Under 'Wrapping Layout', 'Simple Cylindrical Wrap' is selected, and 'Number of revolutions' is 1. 'OK' and 'Cancel' buttons are at the bottom.

This form lets you specify the size and orientation of the cylinder you are machining on and also the axis the rotary axis is aligned with on your machine. After filling in the values and pressing OK the form will close and a new job will be created within the program. The size of the job will match the size of a sheet of paper wrapped around the surface of a cylinder of the size you specified. The thickness of the material will be set to the radius of your cylinder.

- 4) You can now create toolpaths within the job as normal. For this example I have created a piece of text machined with a pocketing toolpath 0.1” deep.

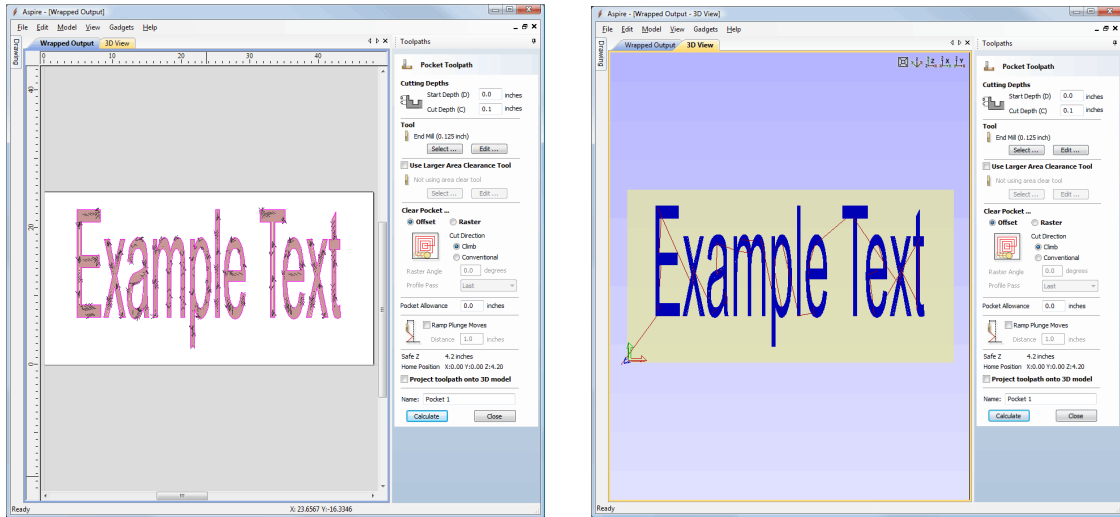

In the 3D view you will see the ‘normal’ 2d toolpath ...

- 5) We can now see what this toolpath will look like when it is ‘wrapped’ for output on a rotary axis. Using the main menu bar select **View- Toolpath Drawing – Wrap Y/X Values (Around X/Y Axis)**

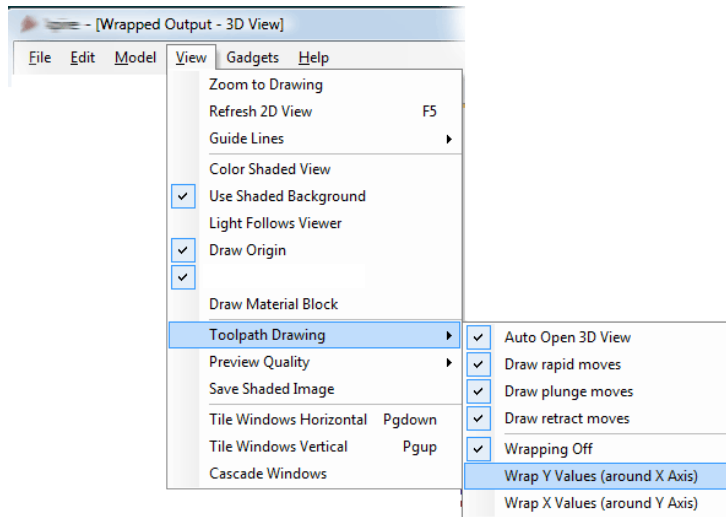

Note that for clarity we have un-checked ‘*Color Shaded View*’ . Depending on your machine setup, you should choose either ‘*Wrap Y Values (around X axis)*’ or ‘*Wrap X Values (around Y axis)*’ and this choice should match the choice you made for cylinder orientation in the ‘*Wrapped Job Setup*’ gadget in step 2.

- 6) In the 3D view you should now see your 'flat' toolpath wrapped around the axis of your choice. To help with visualization, check the menu option 'View – Draw Material Block' as shown in the screen shot below.

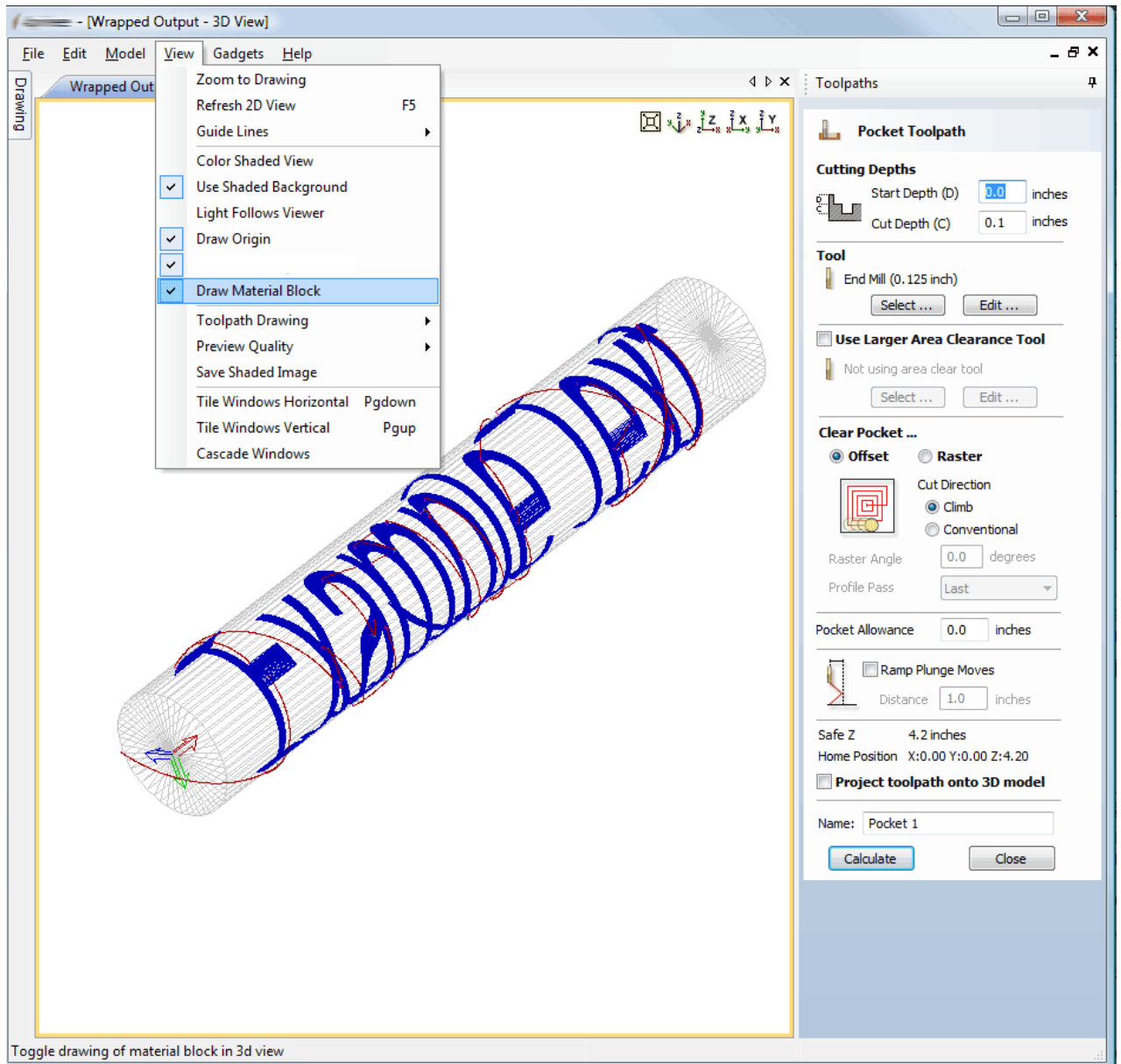

- 7) We are now ready to save the toolpath using the wrapping post-processor we copied into the PostP directory in Step 1. Select your 'Wrapping' post-processor and the 'Wrapped Output' dialog will appear as shown below ...

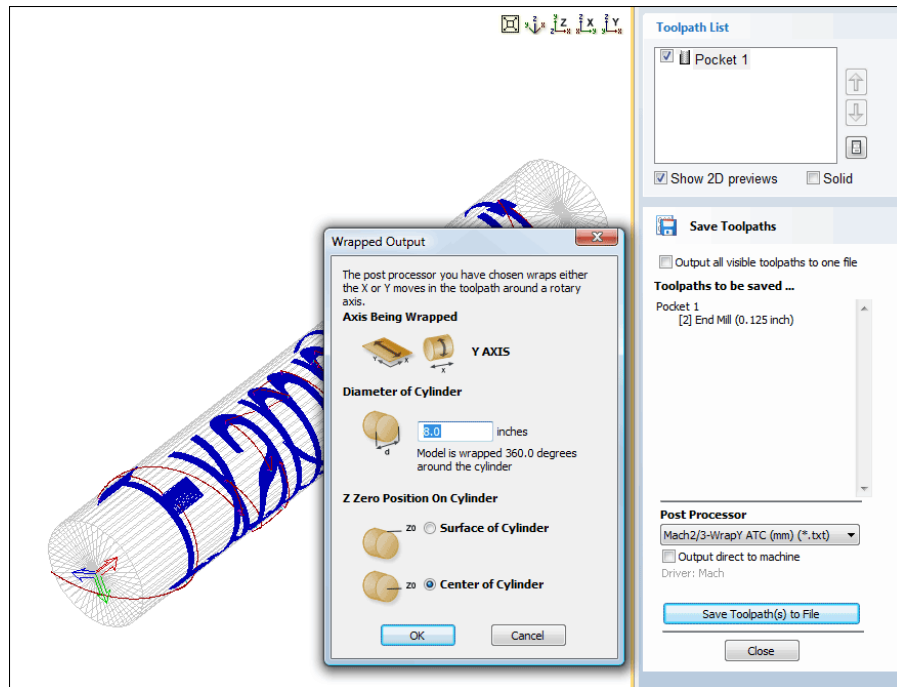

Note that we have selected a wrapping post-processor (it has 'Wrap' as part of the name to distinguish it from a normal post-processor). Normally you will not need to change the values on this form other than 'Z Zero Position On Cylinder' the first time you run it. The rest of the values are filled in automatically based on the settings from the post-processor and the material thickness which should have been set to the radius of your cylinder by the 'Wrapped Job Setup' gadget in step 2.

For the Z Zero position, we would strongly recommend that you choose 'Center of Cylinder' as this should always remain constant irrespective of irregularities in the diameter of the piece you are machining or errors in getting your blank centered in your chuck. A useful tip for doing this is to accurately measure the distance between the centre of your chuck and a convenient point such as the top of the chuck or part of your rotary axis mounting bracket. Write down this z-offset somewhere, and zero future tools at this point and enter your z-offset to get the position of the rotary axis center. If you are roughing an oversize blank, you **MUST** zero from the center of the cylinder, as the 'Surface of Cylinder' option refers to the surface of the final blank **NOT** your rough blank.

This has just been a brief overview of how wrapped machining works, and Vectric supply a number of other 'gadgets' to help perform common rotary machining tasks such as rounding square stock, creating fluted columns, laying out 'barley-twist' spirals etc. These gadgets are documented more fully on the gadget section of the Vectric web-site at <http://www.vec tric.com/WebSite/Vetric/support/gadgets.htm>

Menus

Overview

There are two main places that you can access menu's in VCarve Pro, the first is across the top menu bar as highlighted with a red box in the image shown below:

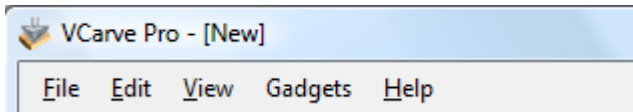

Clicking on any of these options (File, Edit, Model, View, Help) will result in a drop-down menu appearing with choices related to that topic. Many of these are just an alternate way to access functions also accessed through the icons, however there are a few commands though that are unique to the Drop Down menu. Each menu and its contents are discussed later in this section of the manual. Only unique items which do not have an equivalent icon that has already been discussed in the manual will be dealt with in detail.

The second way to access menus is by clicking the RIGHT mouse button in the 2D View which will bring up a pop-up menu. The choices presented in this menu are determined by what is currently selected and where the mouse cursor is positioned in the 2D View. Again the options from this menu are discussed later in this section of the manual.

File menu

Clicking on the File option at the top of the interface will display the following menu:

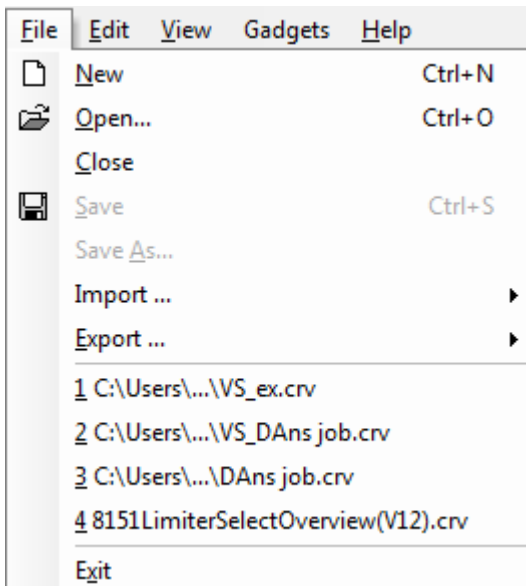

New

Creates a New VCarve Pro job/part file, the same as this icon 

Open

Opens an existing VCarve Pro job, the same as this icon 

Close

Closes the current file but leaves the software running

Save

Saves the current VCarve Pro file (*.crv) over the last saved version of the file

! This will overwrite the old file with any changes made since the last save. If you are not sure of your changes then use the Save As...option and give the file a new name. The same as this icon .

Save As...

Opens the File Save menu, to enable you to save the current file, with a new name.

Import...

Give you options to Import either Vector data or Bitmap data the same as these 2 icons 

Export...

Lets you export selected Vectors as either an eps, ai or dxf format vector file.

Previous four files saved

Displays the names of the last four files which were saved from VCarve Pro – clicking on any of these will automatically open the selected file.

Exit

Closes the part and exits the software

Edit menu

Clicking on the Edit option at the top of the interface will display the following menu:

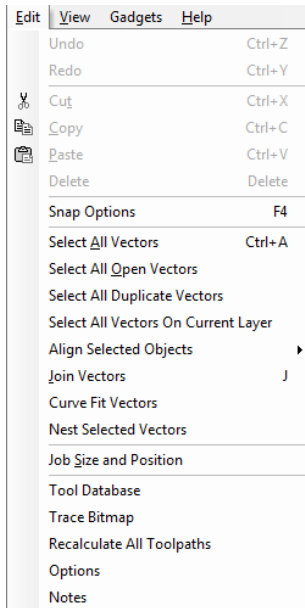

Undo

Clicking this option steps backwards through the last 5 changes made by the user, same as this icon 

Redo

Clicking this option steps forward through design steps that have been Undone using the Undo command (see above) to get back to stage that the user started using the Undo function. The same as this icon 

Cut

Removes the selected objects from the job and places them onto the clipboard, the same as this icon 

Copy

Copies selected objects to the clipboard, leaving the original in place, the same as this icon 

Paste

Pastes the contents of the Clipboard into the model (see cut and copy above), the same as this icon 

Delete

Deletes the selected object – same as hitting the delete key on your keyboard

Snap Options

Opens the Snap Options menu – for details on this see the section on Rulers, Guidelines and the Snap Grid at the end of the 2D Design part of this manual. Shortcut key for this is F4

Select All Vectors

Selects all the currently visible vectors in the part (vectors on invisible layers are not selected)

Select All Open Vectors

Selects all the currently visible Open vectors in the part

Select All Duplicate Vectors

Selects all the currently visible Duplicate vectors in the part – these are vectors which are exact copies of each other in terms of shape and location so that visually they appear to be only one vector. These can cause problems for some toolpath and drawing functions, so it can be useful to delete them or move them to a new layer.

Select All Vectors On Current Layer

Selects all the vectors on the selected layer.

Align Selected Objects

Give the use all the options covered under the Align Objects section of the menu – see the Align Objects section of this manual for more details on all the options.

Join Vectors

Opens the Join Open Vectors command, the same as this icon 

Curve Fit Vectors

Allows arcs, Bezier curves or lines to be fitted to existing vectors to ‘smooth’ them

Nest Selected Vectors

Nest selected vectors to improve material usage.

Job Size and Position

Opens the Job setup form, the same as this icon 

Tool Database

Opens the Tool Database for adding or editing tools

Trace Bitmap

Opens the Trace Bitmap function, the same as this icon 

Recalculate All Toolpaths

Recalculates all the Toolpaths in the part, the same as this icon 

Options

Opens the Program options form.

This form allows the customization of certain aspects of the program.

The options fall into four categories:

- General Settings
- Window Layout
- 3D View Settings
- Toolpath Settings

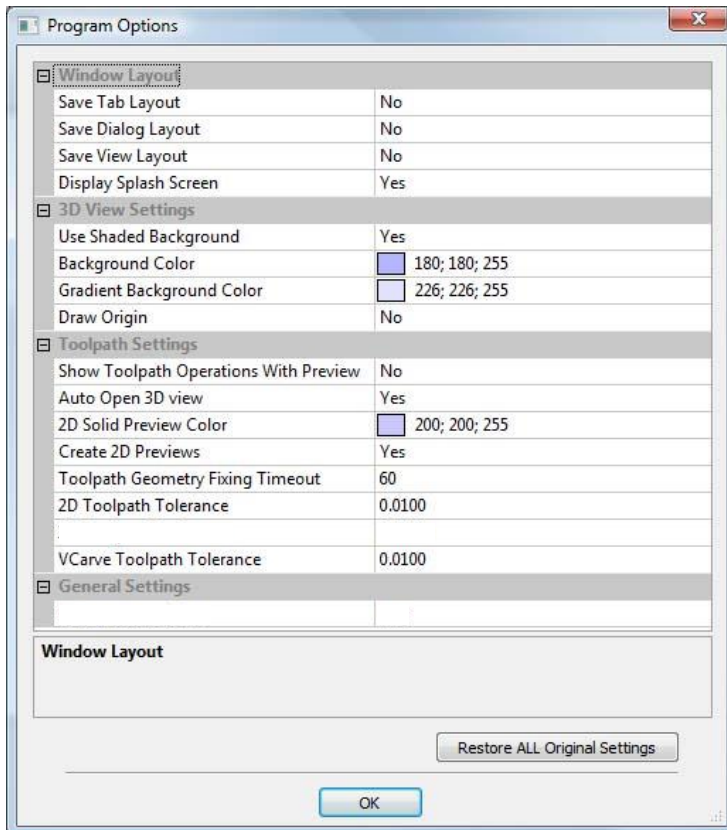

Window Layout

Save Tab Layout

Save the layout and the “pinned” state of the command and toolpath flyout tabs.

Save Dialog Layout

Save the size, position and visibility for dialogs such as the Layer control and Toolpath Control dialogs.

Save View Layout

Save the layout of the 2D and 3D view windows.

Display Splash Screen

Display the program Splash Screen, whilst the program is loading.

3D View Settings

Use Shaded Background

Use a gradient shaded background for the 3D view.

Background Color

Change the background color used for the 3D view, click on the ... button to display the color selection dialog.

Gradient Background Color

Change the bottom (lightest) color used for the 3D view, click on the ... button to display the color selection dialog.

Draw Origin

Draw the origin arrows by default on startup.

Toolpath Settings

Show Toolpath Operations with Preview

When the toolpath **Preview** form is visible, keep the 'Toolpath Operations' section visible. (requires more screen space)

Auto Open 3D view

Automatically swap to 3D view after calculating a toolpath.

2D Solid Preview Color

Color used to draw the solid 2D toolpath preview with.

Create 2D Previews

Create 2D previews of toolpaths in 2D view.

Toolpath Geometry Fixing Timeout

Number of seconds the program will spend trying to fix problems with geometry when calculating toolpaths.

Toolpath Tolerance

We recommend that these values should be left at their default settings unless different values are recommended by your machine tool manufacturer. If you do have a machine which struggles with the default settings, try doubling the values and cutting a test-piece to assess the trade off between machining time, file size and final machined quality. We have done some limited testing and on a sample complex 3D model, increasing the '3D Toolpath Tolerance' to 0.001" gave a 40% decrease in file size and no noticeable difference in quality **on the test machine and job**. In the test case there was no measurable difference in machining time on the CNC machine the test was carried out on.

2D Toolpath Tolerance

Tolerance to apply to 2D toolpaths after calculating to reduce file size.

This setting should only be changed if your machine tool supplier has recommended a value

VCarve Toolpath Tolerance

Tolerance to apply to VCarve toolpaths after calculating to reduce file size.

This setting should only be changed if your machine tool supplier has recommended a value.

General Settings

(There are no current options in this section for VCarve Pro 5.5)

Notes

This opens a text box where you can record notes regarding this job, such as customer name, material required, special setup instructions etc. To allow this, we have added a 'Notes' dialog which can be accessed using 'Edit - Notes' from the main menu bar.

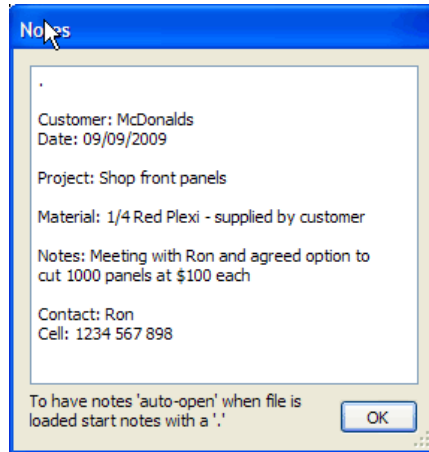

If the text starts with a period / full stop '.', the Notes dialog will be displayed automatically each time the file is opened. The text from the Notes dialog can also be optionally output into the toolpath as a comment field. Please see the 'Post-Processor Editing Guide' for more information on how to do this (using the [FILE_NOTES] variable).

View menu

Clicking on the File option at the top of the interface will display the following menu:

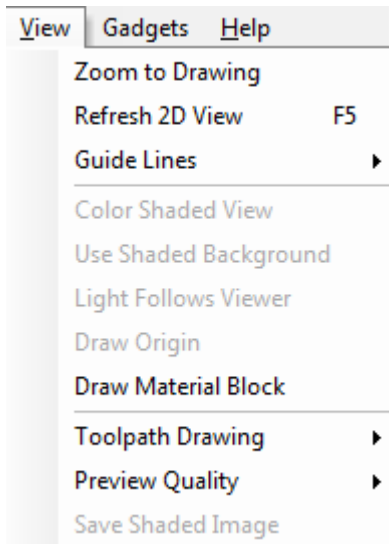

Zoom to Drawing

Zooms the 2D view to fit the current Material size to the window so it shows as large as possible while still displaying the whole material area.

Refresh 2D View

ShortCut key for this is F5. In situations where the complete vector geometry represents a very large job and the user zooms into a small region, the shape of arcs and curves may look faceted. Pressing F5 rebuilds the display information to correct the graphics being drawn on the screen. This is only a display issue and will not impact on the quality of toolpaths.

Guide Lines

Allows Guide Lines to be made visible / invisible in the 2D view and gives access to an option to delete all Guide Lines.

For more details see the section on Rulers, Guidelines and the Snap Grid at the end of the 2D Design part of this manual.

Color Shaded View

Draws / Undraws the color shaded job in the 3D window

Use Shaded Background

Shows either the default gradient filled color background or a solid light blue color background. The solid color is very useful for saving images that need to be cropped out of the background in a graphics software package.

Light follows viewer

The default light setting for the 3D window shines a light onto the job from the top left corner of the material bounding box. Checking this option can sometimes be used to help visualize the job more easily.

Draw Origin

XYZ origin arrows can be toggled on and off in the 3D View to show exactly where the X0, Y0 and Z0 origin is position is relative to the material.

Draw Material Block

Toggles the drawing of a wireframe representation of the limits of the material block. This is useful for seeing how the 3D model will be positioned in the block of material it is being cut from.

Toolpath Drawing

Moving the cursor over the Toolpath Drawing option displays 4 options to control whether the Rapid, Plunge and Retract moves on displayed toolpaths are drawn in the 3D view.

The option to Automatically Open the 3D View after calculating a toolpath can be switched on or off. This option can be very useful when calculating multiple toolpaths that need to be selected in the 2D view, and stops the 3D view and Preview Toolpaths form from being shown.

There are a further 3 options relating to the display of Wrapped toolpaths.

Wrapping Off

This is the default setting. The toolpaths are displayed flat.

Wrap Y Values (around X Axis)

This is the default setting. The toolpaths are displayed flat.

Preview Quality

Controls the quality of the preview display. The speed that the simulation is created will depend upon the selected quality and the performance of the PC.

Standard Quality is the fastest mode and recommended for low performance PC's

High Quality displays good quality images and is for general use

Best Quality gives fantastic images, but may run slower on old PC hardware

Save Shaded Image

Saves a color shaded image of the 3D view as a BMP, JPG or GIF file.

Note Saving the image without the color shaded background is often useful when the image will be used on its own in a brochure or on a web site etc.

Gadgets menu (Optional)

This is an optional menu option that will be present if a 'Gadgets' folder exists within the main installation folder.

Gadgets are small add-on programs, produced by Vectric, which perform specialized tasks. Gadgets are distributed from the Vectric web-site and the list of available gadgets will expand over time. The content of the gadgets menu on the main menu bar is built dynamically when the program starts by scanning the 'Gadgets' directory under the installation folder for the program (usually C:\Program Files\VCarve Pro V5.5\Gadgets). When a file ending with .VectricGadget, .exe or .bat is found in the folder (or sub-folder) an entry is made in the Gadgets menu allowing you to run the program by clicking on its name.

If you want direct access to a program you commonly use, just copy it into the Gadgets directory and restart Aspire and it will appear on the Gadget menu. Please note that many programs require other supporting files to run. An example is Notepad.exe which can simply be copied on its own for early versions of Windows, but for later versions it needs other supporting files and will not run if you just copy notepad.exe into the Gadgets folder. To run a program like this, create a text file with the contents as shown below ..

```
cd "C:\Windows"  
start Notepad
```

and save its as "Run_Notepad.bat" in the Gadgets folder. When you restart the program you will have an entry called "Run Notepad" (NOTE: ' _ ' characters are replaced by a space in the menu entry). Clicking on this should run Notepad.

As well as allowing direct access to other executable programs, Vectric supply a number of 'VectricGadget' gadgets which interact with the program to perform a particular task. A simple example is the Keyhole toolpath gadget which creates a toolpath for machining keyhole slots in the back of your job.

As well as creating the toolpath, the gadget can also create vectors on a separate layer showing the position and extents of the keyhole slot.

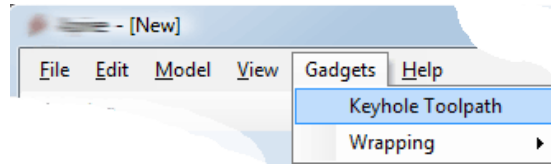

If you run the gadget with no vectors selected, the following message will be displayed ..

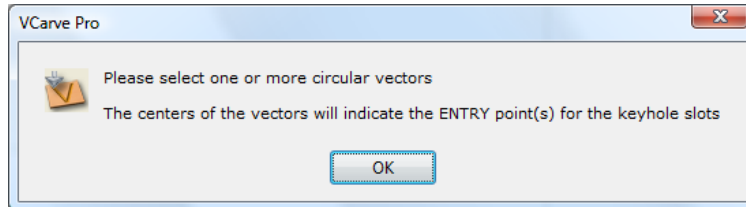

This is because the gadget uses vectors you draw on your design to specify the entry points for the keyhole slots. After you have drawn suitable vectors and selected them, re-running the gadget will display the following dialog...

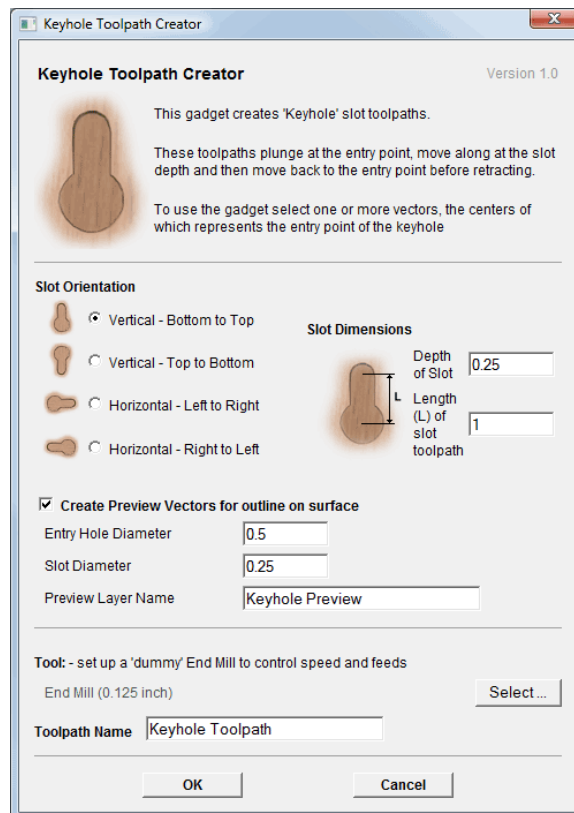

Gadgets are designed to be self-explanatory where ever possible and hopefully by reading the text on the dialog and viewing the results users should find them easy to use.

It is important to point out that the gadgets are NOT as polished as functionality which has been integrated into the main program. The gadget concept is intended to allow Vectric to produce simple add-ons which address minority requirements without cluttering up the main interface. As the Gadget library grows over time, we do not expect users to install every gadget, but only those that may be relevant to tasks they actually perform. We ship some gadgets which help perform common tasks for people with rotary axis. If a user has no interest in rotary machining, they can delete the 'wrapping' gadgets from their gadgets folder and those options will no longer be available from the Gadgets menu.

Documentation and new releases for gadgets will be available from the Vectric web-site at <http://www.vectric.com/WebSite/Vectric/support/gadgets.htm>

Help menu

Clicking on the File option at the top of the interface will display the following menu:

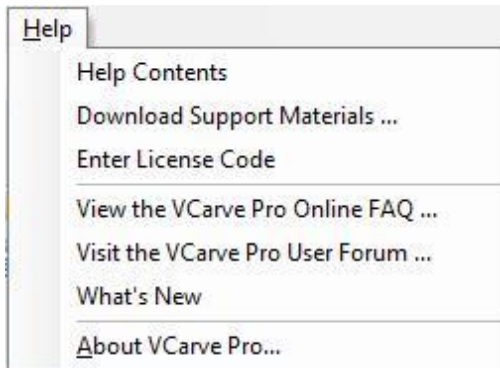

Help Contents

Displays an HTML document which lists all the software functions and has more complete explanations of some of the 2D design tools covered in this manual.

Download Support Materials

When selected it will open a page to download the latest tutorials and support information for VCarve Pro from the Vectric website. This requires a live internet connection to work correctly. Note that most of the support materials for VCarve Pro are supplied on the program DVD.

Enter License Code

The license details provided when you purchase VCarve Pro must be entered into this form. Your Registered User Name and License Code can be Copy and Pasted into the fields to ensure this works correctly. If you have problems then contact Vectric or the company who you purchased the software from ASAP.

View the VCarve Pro Online FAQ

This option opens a browser window and links to the FAQ section on the Vectric web site. This requires a live internet connection to work correctly.

View the VCarve Pro User Forum ...

This option opens a browser window and links to the Vectric User Forum. We strongly recommend that you register and join the forum as this is a very useful source of information from the Vectric Team and Users all over the world. This requires a live internet connection to work correctly.

What's New

This option will open an HTML document in your browser showing new features when software updates are issued.

About VCarve Pro

This window displays the version of the software being used, to whom the software is license and the type of license.

Right Mouse Click menus

Clicking the RIGHT hand mouse button in the 2D View will display a menu with choices which depend the current selection mode (Normal, Node Editing, Scale/Move/Rotate) and also what is currently selected.

2D View Right Mouse Menu

The following menu is displayed when you have a vector selected or if you just RIGHT-click in the white background of the part. Most of these options repeat functions and icons described in this manual, you should refer to the appropriate section to view how these work. The move to Layer option is unique to the Right click menu and lets the selected objects me moved to any Layer or to a newly created Layer.

Undo	Ctrl+Z
Redo	Ctrl+Y
<hr/>	
Cut	Ctrl+X
Copy	Ctrl+C
Paste	Ctrl+V
Delete	Del
<hr/>	
Unselect All	
Select All Vectors	Ctrl+A
Select All Open Vectors	
Select All Duplicate Vectors	
Select All Vectors On Current Layer	
<hr/>	
Group Vectors	
Ungroup Vectors	
Break Text Block Into Lines	
Convert Text To Curves	
<hr/>	
Join Vectors ...	▶
Close Vector ...	▶
Node Edit Mode	N
Guide Lines	▶
<hr/>	
Object Properties ...	
<hr/>	
Move to Layer	▶

Span Editing Menu

If the currently selection mode is set to Node Editing , one of 2 different menus will appear when the user clicks the RIGHT mouse button depending on whether the cursor is currently over a Node or a Span in the selected vector. These menus have functions in them that correspond specifically to this selection and position. The menu below will appear when the cursor is over the Span of a vector in Node editing mode. You can see a variety of choices to convert the span to a Line, Bezier (curve) or Arc, Insert a Point, Cut the Vector at that point or Delete the Span. All these have corresponding Short Cut keys (shown to the right of the command in the menu) which can be selected from the key-board when the mouse is in position (over a node-edit vector span) instead of Right Clicking the mouse button to access the menu.

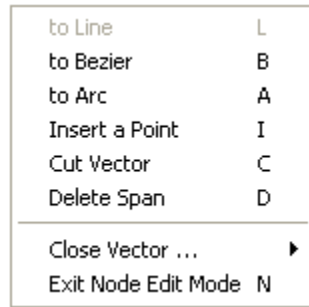

Node Editing Menu

The menu below will appear when the cursor is over the Node of a vector in Node editing mode. You can see a variety of choices to convert the span to Delete the Point, Smooth it, Cut the vector at that point or change the point to be the Start Point on the vector. From this menu you can also Close the vector, Exit the node editing mode and lastly see and edit the exact XY co-ordinate position of the node by selecting Properties. All these have corresponding ShortCut keys (shown to the right of the command in the menu) which can be selected from the key-board when the mouse is in position (over a node-edit vector node) instead of Right Clicking the mouse button to access the menu.

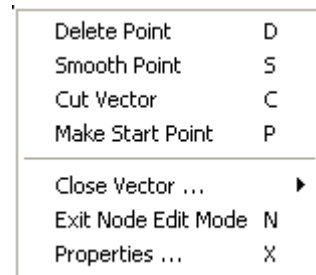

Glossary of Terminology

2D View

Shows the workspace defined when you create a new file. This is used to control the XY layout of vectors and bitmaps. Typically you select an item from this view by clicking on it or dragging a box around it with the mouse. To move it you can click a selected item a second time to go into Transform mode. Some items when double clicked will open a form relating to the object and many have functions related to them displayed when you right mouse click over them.

3D View

This shows the Working Model, visible Components and any visible Toolpaths. Also used to display the Working Model and sculpting brush when using the Sculpting function.

Bitmap

Generic term used to describe any raster (pixel) based image which can imported into VCarve Pro using the Import bitmap for Tracing icon. File types supported are: bmp, jpg, gif, tif, png and jpeg. Bitmaps are primarily used for tracing vectors over to create toolpaths.

File

Generic name most often used to describe a complete VCarve Pro project (CRV file) which contains all the 2D and Toolpath information in a single saved file. Also sometimes referred to as a Part.

Grayscale

2D View representation of an Imported 3D toolpath Used to allow selection and editing of position, rotation etc. Some of the Vector Editing tools also work with the Grayscale's.

Short Cut Keys

Keys on the keyboard which will activate certain commands when pushed. Example F9 to center the selection. You can find a full list of all the Shortcut keys in the Help File (Help – Help Contents) and also in the Frequently Asked Questions section of this manual.

Vector

A 2D object represented by lines, arcs or curves. Used to layout a design for 2D and 2.5D toolpathing.

Frequently Asked Questions

Is there a list of all the Short-Cut keys?

There is a list of all Short-Cut keys below and within the software this can be accessed by clicking on Help from the drop down menus and selecting Help Contents.

Shortcut key	Description
Ctrl A	Select All vectors
Esc	Unselect All vectors
Select Right to Left	Selects all vectors inside and touching selection rectangle
Select Left to Right	Only selects vectors fully inside selection rectangle
N	Toggles between Selection and Node Editing modes
J	Opens the Join form
M	Opens the Move form
T	Opens the Scale form for Transforming the vectors
R	Opens the Rotate form
Ctrl L	Opens the Layers form
Space Bar	Finishes Drawing operation and stays in the same mode.
Z	Zoom - click top left and bottom right corners to zoom
F	Zoom to fit Material
F1	Opens the Help File
F2	Opens the 2D Drawing window
F3	Opens the 3D Preview window
F4	Opens the Snap Settings form
F5	Refreshes the 2D window
F6	Scales 2D view to fit material
F9	Center selected object tin view
F11	Toggle drawing tab on
F12	Toggle toolpath tab on
Groups	
G	Creates a single group containing selected vectors / groups
U	Converts a Group to individual vectors or groups
Arrow keys	Nudge selected vectors using the Arrow keys Holding Ctrl reduces the nudge distance Holding Shift increases the nudge distance
Ctrl + Shift + H	Creates a copy of the selection, horizontally mirrors the selection about the centre of the material.
Ctrl + Shift + V	Creates a copy of the selection, vertically mirrors the selection about the centre of the material.

Node Editing

I	Insert a Point
D	Delete Point / Span
S	Smooth / Unsmooth Point
C	Cut Vector opens the vector
B	Convert span to Bezier
A	Convert span to Arc
L	Convert span to Line
P	Makes the selected node the Start Point for machining

Right mouse click

Quick Edit and Quick View menus

Ctrl Z	Edit Undo
Ctrl Y	Edit Redo
Ctrl C	Copy the selected vectors
Ctrl V	Paste the selected vectors
Ctrl & Drag	Pastes a copy of the selected vectors each time the left mouse button is released.
Ctrl X	Cut the selected vectors
Ctrl N	Create New file
Ctrl O	Open Existing file
Ctrl S	Save file

What file formats can be used?

VCarve Pro will open files that have been saved in the following formats:

Vectors

DXF	Drawing Exchange Files from CAD systems
DWG	Drawing Files from CAD systems
EPS	Encapsulated Postscript from Adobe Illustrator and Corel Draw etc.
AI	Adobe Illustrator
PDF	Portable Document Format for industry standard print data



If the designs are being prepared with software such as Corel Draw or Adobe Illustrator we recommend that you **convert the vector geometry and text to curves** and **switch off all patterns or colour fills** before exporting, **preferably as an EPS file**.

Images

DXF	Drawing Exchange Files from CAD systems
DWG	Drawing Files from CAD systems
EPS	Encapsulated Postscript from Adobe Illustrator and Corel Draw etc.
AI	Adobe Illustrator
PDF	Portable Document Format for industry standard print data

Where can I get Help?

If you need assistance when using the software there are 5 primary places to look.

1. **Program Help File** - From the Main menu select Help
2. **Video Tutorials** - These are supplied on the installation CD or can be downloaded from the Vectric website.
3. **User Forum** - The Vectric user forum at www.vectric.com/forum is a very useful resource for information on VCarve Pro along with materials, cutters etc. and also to share knowledge and experiences.
4. **E-mail Support:** - The Vectric Support Team at support@vectric.com
5. **Frequently Asked Questions (FAQ)** - The support area on the Vectric web site at www.vectric.com maintains a list of the most frequently asked questions along with the answers.

2D View

- Move, Rotate and Scale vectors, bitmaps and imported toolpath 3D grayscales”

3D View

- View shaded image of preview of the finished job.